

SPECIFICATION
FOR
EV School Bus Charger
Residential Installations
Queens County - Various Locations
PEI

Project 709-22065

Prepared by: Matt Collins

PEI Department of Transportation and Infrastructure

July 2023

TABLE OF CONTENTS

No. of Pages

Section A	-	Invitation to Bidders	1
Section 1A	-	General Instructions.....	8
Section B	-	Instructions to Bidders.....	11
Section C	-	General Conditions	18
Section D	-	Form of Agreement.....	2
Section E	-	Tender Form.....	3
Section G	-	Safety Requirements.....	7
Appendix A	-	Special Instructions.....	1
Appendix B	-	Photos.....	3
Appendix C	-	Product Brochures.....	40

DTI Public Works and Planning is moving forward with our capital building repair and construction program and will be issuing tenders as follows:

Tenders will continue to be advertised and posted to the PEI Government tender site:

<https://www.princeedwardisland.ca/en/tenders>

Sealed tenders will be received at the Security Desk at the main entrance to Jones Building, 11 Kent Street, Charlottetown, PEI, CIA 7N8 until **2 PM, Local Time, on Tuesday, August 15, 2023**. Tenders are to be clearly marked to indicate the project being tendered on.

EV School Bus Charger Residential Installations - Queens County - Various Locations

Scope of Work:

1. Install supplied EV School Bus Chargers

Hard copies (paper copies) of tender documents will **not** be made available to bidders at this time. All tender documentation will only be available electronically. Electronic documents will be posted electronically to the Government tender page:

<https://www.princeedwardisland.ca/en/tenders>

Electronic documents will be issued to Construction Association of PEI (CAPEI) as well as to NB and NS Construction Associations. Addenda will only be posted to the Government tender site and issued to the Construction Associations. **It is the Contractor's responsibility to ensure that they have incorporated all addenda into their bid submission.**

- Tender envelopes must be clearly marked with the project Name.
- Tender documents will need to be received prior to 2PM on the date specified in the tender.
- No submissions will be accepted after that time.
- The tender opening will be opened to the public.
- Tender envelopes will be opened immediately after the tender closing

Refer to Instructions to Bidders for Bid Security and Contract Security requirements.

Lowest or any Tender will not necessarily be accepted.

Any additional information can be obtained by contacting

Matt Collins – Manager Engineering Services, at 902-620-3323 or at mcollins@gov.pe.ca

Stephen Szwarc – Director Highway Maintenance, at 902-368-5103 or at sjszwarc@gov.pe.ca

1. GENERAL

- a) The General Contractor is to provide each item and properly execute all work as specified herein, indicated by drawings, specifications, addenda, or change orders issued with respect to this Project.
- b) The General Contractor shall co-ordinate, administer and supervise all work and material acquisition unless noted otherwise in either the Specifications or Drawings. Faulty work by any Section which could have been avoided by proper co-ordination and/or supervision by the General Contractor will not be accepted.
- c) Unless specified otherwise, the provisions of this Section shall apply to all Sections of the specifications.
- d) Study all Contract documents to determine additional work required by your section on which the work of other sections depends.
- e) Establish rates of wages and conditions of work in accordance with the Employment Standards Act of the Province of Prince Edward Island. Wherever possible give preference to local labour.
- f) Workmanship shall be of highest quality in accordance with best standard practice for this type of work, except where specified more precisely.

2. SPECIFICATION FORMAT

- a) These specifications are not intended as a detailed description of installation methods but serve to indicate particular requirements in the completed work.
- b) Conform to the latest edition of the National Building Code, together with all its related supplements, hereinafter referred to as the “Code” or “code”. Where Drawings and Specifications exceed code requirements provide such additional requirements.
- c) Where a material is designated on Drawings or in the Specifications for a certain application, unless otherwise specified, that material shall conform to standards designated in the latest edition of the National Building Code and any other Code, Act or Bylaw of Provincial or Local Application provided that in the case of conflict or discrepancy the more stringent requirement shall apply. Similarly, unless otherwise specified, installation methods and standards of workmanship shall also conform to standards invoked by the aforementioned code. Where no particular material is specified for a certain use, the bidder shall select from the choice offered in the code in each case.

-
- d) References to codes, and standards, including manufacturer's direction for installation shall be the latest edition thereof.
 - e) Provide a copy of all certificates of acceptance issued by Provincial or Local authorities.
 - f) Parts of the specification are written in short form, therefore it is understood that where a component of the work is stated in a heading followed by a material or operation, the words "Shall be", "Shall consist of" or similar words or phrases are implied which denote complete supply and installation of such materials of operations for the component of work designated by the heading.
 - g) Where the aforementioned Code or this specification does not provide all information necessary for complete installation of any item, then the manufacturer's instructions for first quality workmanship shall be strictly complied with.
 - h) Where words in the Contract Documents occur in the singular number, they shall be taken as plural where applicable in accordance with the quantities required to satisfy the requirements of the Contract.

3. STANDARDS AND DEFINITIONS

- a) Where a reference is made to specification standards produced by various organizations, conform to latest edition of standards, as amended and revised to date of Contract.
- b) Have a copy of each specified standard which relates to your work available on the Site to be produced immediately on the Consultant's request.

4. CO-OPERATION

- a) Co-operate with and co-ordinate with other trades as required for the satisfactory and expeditious completion of the work. Take field dimensions relative to this work. Fabricate and erect work to suit field dimensions and field conditions. Provide all forms, templates, anchors, sleeves, inserts and accessories required to be fixed to or inserted in the work and set in place or instruct the related trades as to their location. Pay the cost of extra work caused by and make up time lost as the result of failure to provide the necessary co-operation, information or items to be fixed to or built in, in adequate time.
- b) This Section shall provide other Sections with and be responsible for levels and dimensions which other sections require for establishing proper locations for their work.

5. MATERIAL STORAGE AND HANDLING

- a) Store packaged materials in original, undamaged condition with manufacturers' labels and seals intact. Handle and store materials in accordance with manufacturers' and suppliers' recommendations and in a manner to prevent damage to materials during storage and handling.

6. SITE VISIT

- a) All bidders submitting tenders for this work shall first examine the site and all conditions therein. All tenders shall take into consideration all such conditions as may affect the work under this contract, no claims for extras resulting from conditions existing at the time of tender will be accepted by the Owner.

7. EXAMINATION

- a) All trades shall examine the existing conditions upon which their work depends. Report to the General Contractor with a copy to the Consultant in writing defects in such work. The application of their work or any part of it shall be deemed acceptance of the work upon which their work or that part of it which has been applied depends.
- b) Drawings are, in part, diagrammatic and are intended to convey scope of work and indicate general and approximate location, arrangement and sizes of building components.

8. CONSTRUCTION SAFETY

- a) Observe construction safety measures of the latest edition of the National Building Code Part 8, Provincial Government Workers/Workers Compensation Board and municipal authority provided in any case of conflict or discrepancy more stringent requirements shall apply.
- b) Comply with requirements of FCC no. 301.
- c) Ensure no part of Work is subjected to loading that will endanger its safety or will cause permanent deformation.
- d) Design and construct falsework in accordance with CSA S269.2.
- e) Operate such equipment only by qualified hoist or crane operators and maintain current inspection certificate.
- f) Design and construct scaffolding in accordance with CSA S269.2.

- g) Comply with the requirements of the Fall Protection & Scaffolding Regulations, Province of Prince Edward Island.
- h) Each user of equipment or tools shall be appropriately trained and be responsible to examine for sufficiency before use. Make equipment and tools safe if necessary or notify the Contractor in writing that user will not commence work with such tools until it is made safe.
- i) Comply with the requirements of Workplace Hazardous Materials Information System (WHMIS) regarding use, handling, storage, and disposal of hazardous materials; and comply regarding labeling and provision of material safety data sheets.

.1 Have a copy of WHMIS data sheets available at the workplace on delivery of materials.

9. PROTECTION

- a) Take reasonable and required measures, including those required by authorities having jurisdiction to protect the public and those employed on work from body harm and to protect adjacent public and private property from damage. Make full restitution for such harm and damage resulting from failure to take adequate protective measures. Make good damage to work from whatever cause.
- b) Take all necessary precautions to guard site, premises, materials and the public at time other than when supervised work is in progress.
- c) Provide and maintain in working order, suitable Underwriters' labeled fire extinguishers and locate in prominent position to approval of authorities having jurisdiction.
- d) Provide all signs, ramps, barricades, and hoarding and protective measures necessary to the safe execution of the work and protection of the public.
- e) Protect, relocate and maintain existing, active services wherever they are encountered. Wherever inactive services are encountered, cap them off and remove the unwanted portion, with the approval of the authorities having jurisdiction or the public utility concerned, in the manner approved by them.
- f) All trades shall protect previously installed work while carrying out their own work.
- g) Damaged work shall be made good by appropriate trades but at the expense of those causing damage.

-
- h) Attach and fasten fixtures and fittings in place, in a safe, sturdy, secure manner so that they cannot work loose or fall or shift out of position during the occupancy of building as a result of vibration or other causes in normal use.
 - i) Protect existing buildings, landscaping, curbs, roads and lanes and utilities. If, during work, any buildings, landscaping, curbs, roads and lanes are damaged, repair or replace them at no extra expense to the Owner.
 - j) Provide safety helmets for Consultants, Owner's representatives and any other authorized visitors to site if required.

10. FASTENINGS

- a) Supply all fastenings, anchors and accessories and adhesives required for fabrication and erection of the work.
- b) Exposed metal fastenings and accessories shall be of same texture, colour and finish as base metal on which they occur.
- c) Exterior anchors for windows and roofing sheet metal and anchors occurring on or in an exterior wall shall be noncorrosive or hot dip galvanized steel.
- d) Anchoring and fastening devices or adhesive shall be of appropriate type and shall be used in sufficient quantity in such a manner as to provide positive permanent anchorage of the unit to be anchored in position. Install anchors at spacing to provide for required load carrying capacity.
- e) Keep exposed fastenings to a minimum, evenly spaced and neatly laid out.
- f) Supply adequate instructions and templates and, if necessary, supervise installation where fastenings or accessories are required to be built into work of other trades.
- g) Fastenings shall be of permanent type. Wood plugs are not permitted.
- h) Fastenings which cause spalling or cracking of material to which anchorage is being made are not permitted.
- i) Do not use powder actuated fastening devices, which are stressed in withdrawal on any part of this work without written approval from the Consultant. Take particular stringent safety precautions when using powder actuated fastenings. Only low velocity plunger-type are permitted.

11. CUTTING, FITTING, AND PATCHING

- a) All cutting and patching shall be the responsibility of the General Contractor.
- b) All excavation backfilling and concrete work required to complete the work of Section 15 and or Section 16 shall be the responsibility of the General Contractor.
- c) Where new work connects with existing and where existing work is altered, cut and patch and make good to match existing work.
- d) Make cuts with clean, true, smooth edges. Make patches inconspicuous in final assembly.

12. EXISTING SERVICES

- a) Where work involves breaking into or connecting to existing services, submit work schedule sufficiently in advance to allow coordination of possible interruption with the Owner. Confirm each interruption 24 hours immediately prior to scheduled date of implementation.

13. ENVIRONMENTAL PROTECTION

- a) Ensure that pollution and environmental control of construction activities are exercised during the work to requirements of the federal and provincial environmental acts; including, but not limited to, the Prince Edward Island Environmental Protection Act.

14. HAZARDOUS MATERIAL

- a) Should material resembling hazardous materials (other than those identified within the Contract Documents), including, but not limited to spray or trowel applied asbestos, be encountered in course of work; stop work immediately. Do not proceed until written instructions have been received from Consultant.
- b) Any material which contains asbestos that is disturbed or removed during construction work (see Asbestos Content Report (where applicable)), shall be removed in accordance with the regulations set out by the Occupational Health & Safety Act. All costs for proper cutting, removal and disposal of all asbestos on this contract shall be included in Tender. Refer also to Section 2C (as applicable).
- c) Where work entails use, storage, or disposal of toxic or hazardous materials, chemicals and or explosives, or otherwise creates a hazard to life, safety, health, or the environment; work shall be in accordance with the Jurisdictional Authority.

15. CLEANING

- a) All rubbish and construction debris must be removed from the entire site on a regular basis, so that the site is maintained in a clean, safe condition. Materials removed are to be disposed of in a manner acceptable to the Provincial Department of Communities, Land & Environment.
- b) Vacuum clean all areas prior to painting and close all areas after completion of painting to restrict access to authorized persons.
- c) On completion of work, by other trades, mop clean all resilient flooring strip using wet method to remove all layers of new or existing finish. Reseal with one coat sealer and two coats wax (wax to contain a minimum of 22% solids). Vacuum clean all carpets. All cleaning to be carried out by competent cleaners.
- d) Dust and clean all surfaces including glass (interior and exterior), doors and hardware.
- e) Arrange and pay for replacement of heating, ventilation and air conditioning filters if operated during construction.

16. FIRES

- a) Do not light fires of any sort to burn rubbish resulting from the work.

17. ACCESS TO SITE

- a) Access to site shall be directed by the Consultant.

18. SITE LIMITS

- a) The limits of the site are shown on the drawings and all activity relating to the contract shall be confined within these limits.

19. MAINTENANCE MANUALS

Prior to the issuance of the final certificate the following items shall be assembled and incorporated into a three-ring binder complete with table of contents:

- a) All warranties and guarantees submitted by manufacturers.
- b) The printed or typewritten copies of recommended maintenance procedures for all items requiring regular maintenance.

- c) A copy of all approved Shop Drawings.

20. PERMITS

- a) Obtain and pay for all required permits, licenses, and inspections; required by applicable laws and regulations. Except the building permit which will be paid for by the Owner.

21. TOBACCO PRODUCT USAGE BAN

The use of Tobacco products is not permitted within the building or property.

- a) Property – Includes all lands and buildings under the control of the Government of PEI.
- b) Tobacco Products – Includes cigarettes, cigars, pipes, chewing tobacco, snuff, and any other products containing or reasonably resembling tobacco or tobacco products except approved cessation products used in approved cessation programs.
- c) Tobacco Usage Ban – Includes smoking, chewing, dipping or any other form of use of tobacco products.

END

1. GENERAL

- a) The Tender Documents including General Conditions of Contract, the Instructions to bidders, Specifications, Tender Form and Drawings are all complementary and shall be read together.
- b) Each Tenderer shall examine the Tender Documents as soon as possible after receipt thereof and should he or she discover any errors or omissions therein, he or she shall notify the Department as soon as possible and at least seven (7) days prior to the date set for receiving tenders so that further instructions and/or drawings may be issued to all Tenderers before the date set for receiving tenders.

2. ADDENDA

- a) Tenders may, during the tendering period, be advised by addenda of required additions to, deletions from, or alterations to the requirements of the tender documents. All such changes shall become an integral part of the Tender Documents and shall be allowed for in arriving at the fixed sum tender figure. Addenda will only be posted to the Government tender site and issued to the Construction Associations. **It is the Contractor's responsibility to ensure that they have incorporated all addenda into their bid submission.**

3. BID AND CONTRACT SECURITY

BID SECURITY

- a) Each Tender submitted shall be accompanied by the following security:

- .1 General Contract Tender less than or equal to Three Million (\$3,000,000.00) Dollars, including mechanical and electrical subcontract values:

A Bid Bond equal to at least ten percent (10%) of the Tender amount and a Letter of Surety from a bonding company guaranteeing to supply a Performance Bond in the amount of fifty percent (50%) of the total contract amount.

OR

A Security Deposit equal to at least ten percent (10%) of the Tender amount.

- .2 General Contract Tender more than Three Million (\$3,000,000.00) Dollars, including mechanical and electrical subcontract values:

A Bid Bond equal to at least ten percent (10%) of the Tender amount and a Letter of Surety from a bonding company guaranteeing to supply a Performance Bond in the amount of fifty

percent (50%) of the total contract amount and a Labour and Material Payment Bond in the amount of fifty percent (50%) of the total contract amount.

- b) .1 All Bonds and Letter of Surety, provided by General Contractors, made payable to the Owner.
- .2 Bonds and Letters of Surety supplied by the General Contractor to the Owner shall be from a recognized surety company, satisfactory to, and approved by the Owner.
- c) .1 Security Deposits, provided by General Contractors, must be in the form of a Certified Cheque or Bank Draft drawn on a Bank to which the Bank Act applies or a Credit Union, payable to “**Minister of Finance, Province of Prince Edward Island**”.

OR

- .2 Bond of the Government of Canada, unconditionally guaranteed, as to the principal and interest by the Government of Canada if such Bonds are:
 - (a) Payable to the bearer, or
 - (b) Accompanied by a duly executed instrument of transfer to the Owner, in the form prescribed by the Domestic Bonds of Canada Regulations, or
 - (c) Negotiated as to principal or as to principal and interest in the name of the Owner, pursuant to the Domestic Bonds of Canada Regulations.
- d) Security deposits submitted through the Bid Depository shall be accompanied by the Bid Security. The subcontractors shall advise General Contractors what form of bid security is being used and what form of contract security will be used.

CONTRACT SECURITY

- a) Upon award of a contract the Contractor is to provide the following contract security:
 - .1 General Contract Tender less than or equal to Three Million (\$3,000,000.00) Dollars, including mechanical and electrical subcontract values:

A Performance Bond in the amount of fifty percent (50%) of the contract amount.

OR

A Security Deposit in an amount equal to at least ten percent (10%) of the contract amount.

.2 General Contract Tender more than Three Million (\$3,000,000.00) Dollars, including mechanical and electrical subcontract values:

A Performance Bond and a Labour and Materials Payment Bond, each in the amount of fifty percent (50%) of the contract amount.

- b) .1 All bonds, provided by General Contractors, are to be made payable to the Owner.
- .2 Bonds shall be from a recognized surety company, satisfactory, and approved by the Owner.
- .3 If a Performance Bond is utilized, it shall be maintained in force for a period of not less than twelve (12) months after the issuance of the total Performance Certificate.
- c) .1 Security Deposits, provided by General Contractors, must be in the form of a Certified Cheque or Bank Draft drawn on a Bank to which the Bank Act applies or a Credit Union, payable to “**Minister of Finance, Province of Prince Edward Island**”.

OR

- .2 Bonds of the Government of Canada, unconditionally guaranteed, as to the principal and interest by the Government of Canada if such Bonds are:
 - (a) Payable to the bearer, or
 - (b) Accompanied by a duly executed instrument of transfer to the Owner, in the form prescribed by the Domestic Bonds of Canada Regulations, or
 - (c) Negotiated as to principal or as to principal and interest in the name of the Owner pursuant to the Domestic Bonds of Canada Regulations.
 - (d) Contract security shall be provided at the expense of the Contractor, bonds shall be provided by an established surety company satisfactory to, and approved by the Owner. Certified Cheques or Bank Drafts shall be drawn on an account with a recognized financial institution.
 - (e) Contract security submitted by subcontractors, to General Contractors, shall be in a form satisfactory to the General Contractor.

4. CONSTRUCTION SCHEDULE

- a) Work is to begin immediately following contract award unless indicated otherwise.

- b) The completion date for this project shall be **September 30, 2023**.
- c) Contractor to provide a construction schedule, safety policy, proof of insurance and signed contract documents prior to starting work.

5. MATERIALS AND EQUALS

- a) Materials, plant and equipment are described and named specifically in the Specifications ONLY to describe types and qualities of materials, plant and equipment required.
- b) Suppliers or manufacturers wishing to have their material, plant or equipment approved as an equal shall submit complete technical information to the Consultant seven (7) days prior to the receipt of tenders. The Consultant shall review the material submitted and notify all prospective bidders of any materials, plant or equipment that have been accepted as equal.
- c) All bidders submitting a tender shall include in their tender amount only materials, plant or equipment as specified or that have been approved as an equal.

6. ALTERNATE PRODUCTS

- a) Approval may be given by the Consultant after the award of the Contract, on application in writing from the Contractor, for the substitution of a similar material, item or plant or equipment bearing another brand name or of other manufacture, subject to the following:
 - .1 Any top quality material or item of plant and equipment proposed as a substitute by the Contractor and considered by the Engineer to be of equal quality, value and price to that specified and suitable for the purpose intended, may be accepted as a substitute.
 - .2 Materials and items of plant and equipment which the Contractor proposes as substitutes and which are considered by the Engineer to be suitable for the purpose intended, but which are in their opinion of lesser value, quality and price than those specified will only be accepted as substitutes if reasonable credits are allowed for their use.
 - .3 Requests for alternates must be made by the Contractor well in advance of the time the item is to be ordered. The request shall be accompanied by sufficient information in the form of manufacturers literature, samples, and other data to permit proper investigation of the substitutes proposed.
- b) Bidders are requested to include information on alternates as an appendix to this tender. The information should indicate the proposed credit or extra, to the tender amount, and include sufficient data to allow the Consultant to evaluate the item proposed as an alternate.

7. SUPERVISION AND COORDINATION

- a) The Contractor shall be responsible for supervising and coordinating all aspects of the work.
- b) The Contractor shall include in their quotation all cost relative to supervising sub-Contractors, including those submitting tenders directly to the Owner, which form a portion of the complete project and shall be assigned to the successful General Contractor.

8. RESPONSIBILITY

- a) The Contractor shall be responsible to be fully familiar with the complete documents and shall include in their tender those items which are named, implied, or traditionally a part of the general contract work.

9. DEFINITIONS

In this specification the following terms shall have the definitions noted below:

OWNER: **Government of Prince Edward Island as represented by the Minister of Transportation and Infrastructure**

CONSULTANT: PEI Dept. of Transportation and Infrastructure

10. SITE INSPECTOR

- a) There will be an Inspector representing the Department of Transportation and Infrastructure, Province of PEI. No work is to be covered without having received approval from the Inspector. The Inspector will have the authority to cause any part of the work to cease, should, in their opinion, there be a cause to do so.

This work shall be examined by the Department and approval granted to resume when a satisfactory solution has been found.

- b) The inspector does not have authority to authorize changes to work. He or she shall confer with the Consultant or Engineer who, if necessary, will authorize any change.
- c) The fact that the inspector does not reject any work shall not remove the responsibility for completing all work as specified; from the Contractor.

11. OWNERS RIGHT TO TERMINATE CONTRACT

- a) The Owner reserves the right to remove the Contractor from the site if the work is not completed as specified in Paragraph 4. If the Contractor is removed, the Owner shall have the

work completed and deduct the cost of this work from the amount owing the Contractor and their bid deposit.

12. SUB-CONTRACTORS

- a) Bidders shall include with their tender, in the space in **Section E – Contract Tender**, Appendix A, the name of each Subcontractor and/or Supplier, as designated, whose price has been included in their tender and who will perform the trade work. Substitution for another Subcontractor in the event that the listed Subcontractor is unable to do the work shall be subject to the approval of the Owner and contingent on evidence satisfactory to the Owner that the original Subcontractor's price was legitimately carried in the Tender, and that the original Subcontractor is now incapable of carrying out the work required under the subcontract, or that he refuses to carry out the work and provides documented reasons for such incapability or refusal.
- b) The term "Own Forces," as a subcontractor, may be used by a Bidder where the Bidder is equipped to and in fact normally carries out the trade work using employees in the direct employment of the Contractor or a wholly owned subsidiary company. Other designations such as "Own Estimate" are unacceptable and may be cause for rejection of the tender by the Owner. **Carrying Subcontractor options next to identified work will not be acceptable.**
- c) When a Bidder indicates "Own Forces" as a subcontractor, the Bidder may be required to demonstrate to the Owner that he has the resources, experience and employees necessary, available and qualified to perform the trade work in a manner and quality satisfactory to fulfill the obligations of the Contract Documents and that the trade work is a normal and continual part of his business.
- d) A Bidder, whose tender is accepted, that included "Own Forces" for a subcontract will if requested, provide the Owner with payroll records verifying that the employees carrying out the "Own Forces" subcontract work are direct employees of the Contractor or of a wholly owned subsidiary company of the Contractor.
- e) All Sub-Contractors are advised to become familiar with all Specifications and Drawings. The General Contractor shall ensure that all sub-trades understand their entire responsibilities in order to complete the project. Sub-trade work may appear in various sections of Specifications and on various drawings.

13. GUARANTEES

- a) The Contractor shall be required to guarantee the work of this Contract for a period of twelve (12) months after the Owner's acceptance of the work, against improper or defective materials and workmanship, and shall repair and make good at their own expense any damage to the

building and contents through any of the above causes during this period. Any contract omissions and/or deficiencies reported to the Contractor within twelve (12) months after acceptance of the work shall be made good by the Contractor at their own expense.

- b) Notwithstanding the above, the bidder's attention is directed to the fact that certain individual items on this project may be required to be guaranteed by the manufacturer for periods in excess of twelve (12) months. These specific requirements are to be found in various sections of the Specifications for this project.

14. OFFER ACCEPTANCE/ REJECTION

- a) Duration of Offer:

- a. Bids to remain open to acceptance, and irrevocable for 30 days after Bid closing date.

- b) Bid Evaluation:

The Consultant and Owner will evaluate Bids submitted for this project. The criteria considered in evaluating the Bids and awarding the Contract will include a combination of:

- a. Bid amount;
 - b. Scheduling;
 - c. Compliance;
 - d. Expertise and experience;
 - e. Past performance of the Bidder on projects for the Owner, including:
 - a. Quality of work
 - b. Ability to complete project on schedule
 - c. Ability to organize work activities and subcontractors;
 - f. The Bidder's qualifications to perform the Work, the Bidder's financial capacity to do the Work and the competency of the Bidder;
 - g. Qualifications of the Bidder and named Subcontractors/Suppliers (see paragraph 12. Subcontractors); and
 - h. Any other conditions as may be determined by the Owner to be in the best interests of the Owner. A decision on acceptance of a Bid will be made by the Owner based on the results of the Consultant and Owner's evaluation.
- c) Acceptance of Offer:
 - a. Owner reserves right to accept or reject any or all offers.
 - b. The lowest or any Bid will not necessarily be accepted.

- c. Bids submitted which indicate “Own Forces” for subcontract work, that in the opinion of the Owner cannot be successfully completed by the Bidder’s employees will not be accepted.
- d. Bids not submitted on the required form will be rejected.
- e. Bids which are incomplete or qualified will be rejected.
- f. This Bid creates no obligation on the part of the Owner to award the contract or to reimburse proponents for the proposal preparation expenses. The Owner reserves the right to accept or reject any and all proposals, in whole or in part, received as a result of this request, and to negotiate in any manner necessary to best serve the interest of the Owner.
- g. All Bidders acknowledge that they have no claim against, or entitlement to damages from the Owner of the Consultant by reason of the Owner’s rejection of their individual Bids or all Bids.
- h. Following acceptance of the Bid by the Owner, the Consultant will issue a written notice of acceptance to the successful Bidder.
- i. Following acceptance of a Bid, the Owner will return Bid Security Deposits that were submitted with Bids which were not accepted.

15. CONSULTANT’S INTERPRETATION

- a) The Consultant’s interpretation of plans and specifications shall be final. Should the Contractor have any doubt as to interpretation, he or she shall refer to the Consultant for clarification before submitting their tender. No allowances or extras will be made for misinterpretation of plans and specifications by the Contractor.

16. PERMITS, REGULATIONS AND TAXES

- a) All permits and fees required for the proper completion and inspection of the work herein specified will be paid for by the Contractor. Except the building permit which will be paid for by the Owner. All applicable taxes shall be included in the tender price, excluding the Harmonized Sales Tax. The Contractor, as per current Provincial Regulations, shall include on all invoices the Harmonized Sales Tax as an additional line item. This would be in addition to the tender amount which does not include HST.
- b) The work shall be completed to the satisfaction of the Consultant and local inspecting authorities.
- c) In the absence of any provisions contained herein, the applicable Provincial Codes or the National Building Code shall govern in that order.

- d) The latest edition of the Canadian Electrical Code shall govern all Electrical work, whether prewired and/or assembled remote from the site or not.
- e) All equipment supplied or installed shall be CSA approved for the intended use.
- f) All materials, components and equipment as well as construction methods shall comply with the latest edition of the National Building Code and all other applicable codes or regulations.
- g) The latest edition of the PEI Occupational Health and Safety Act and Regulations shall govern safe construction practices.

17. EXISTING CONDITIONS

- a) Bidders will be held to have examined the Tender Documents, to have visited the site and to have informed themselves as to existing conditions and limitations.
- b) If in the performance of the contract, subsurface or latent conditions at the site are found to be materially different from those indicated by the drawings and specifications, or unknown conditions not usually inherent in work of the character shown and specified, the attention of the Consultant shall be called immediately in writing to such conditions before they are disturbed. Upon such notice, or upon their own observation of such conditions, the Consultant shall promptly make such changes in the drawings and specifications as he or she finds necessary to conform to the different conditions and any increase or decrease in the cost shall be adjusted as provided under “Changes in the Work”.

18. RECEIPT AND OPENING OF TENDERS

- a) Tenders will be opened at the time and place stated in the tender call. The officer whose duty it is to open them will decide when the specified time has arrived. No responsibility will attach to any officer for the premature opening of a bid not properly addressed and identified.

19. AWARD OF CONTRACT

- a) If the tender is accepted the Contract will be awarded as promptly after the opening of bids as is possible. The selection of the tender that is accepted shall be at the sole discretion of the Owner.
- b) Each bidder shall be prepared, if so requested by the Owner, prior to the award of the Contract to present evidence of their experience, qualifications and financial ability to carry out the terms of the Contract.

20. TENDER SUBMISSION

- a) Tenders must be submitted on the form included with this specification. This form must be completely filled out in ink or be typewritten with the signature in longhand. The completed forms shall be without interlineations, alteration or erasures.
- b) The tender, together with the Tender Security described in this section must be addressed and delivered in a sealed envelope marked “Tender” and bearing the name of the Contractor submitting the tender, together with identification indicating the name of the project.
- c) Tenders will be received at the place and time indicated in the tender call. Late tenders will not be accepted and will be returned unopened to the tenderer.
- d) Amendments to the submitted offer will be permitted if received in writing prior to tender closing and if endorsed by the same party or parties who signed and sealed the offer. Amendments submitted by fax will be accepted, if received prior to tender closing. (Fax (902) 569-0590).
- e) The receipt of addenda for the project shall be acknowledged by filling in the addendum number and date of issue for each addendum on the appropriate line in the tender form. These lines shall be initialed by the person signing the tender after they have been filled in.
- f) Any appendices to the tender form requesting information on suppliers, sub-contractors or alternate prices shall be filled in for the tender to be considered complete.

21. TAXES

- a) All tenders submitted shall EXCLUDE the Harmonized Sales Tax.

22. CONFIDENTIALITY AND FREEDOM OF INFORMATION (Effective November 1, 2002)

- a) By submitting your bid, you agree to disclosure of the information supplied, subject to the provisions of the Freedom of Information and Protection of Privacy (FOIPP) Act.
- b) Anything submitted in your bid that you consider to be “confidential information” because of its proprietary nature should be marked as “CONFIDENTIAL” and will be subject to appropriate consideration under the Freedom of Information and Protection of Privacy Act.
- c) During the delivery and installation of goods and/or services, you may have access to confidential or personal information. Should this occur, you must ensure that such information is not released to any third party or unauthorized individual.

- d) Any information provided on this contract may be subject to release under the Freedom of Information and Protection of Privacy Act. You will be consulted prior to the release of any information.

23. HEALTH AND SAFETY COMPLIANCE REQUIREMENTS – POLICIES AND PROTOCOLS

- a) Contractor to follow all Government Health and Safety policies and protocols as required by the project's facility or property onto which the work must occur. Such policies and protocols must be reviewed and discussed prior to the start of the work on the site.

END

INDEX

1. Definitions
2. Documents
3. Detail Drawings & Instructions
4. Copies Furnished
5. Shop Drawings
6. Drawings & Specs on the Work
7. Ownership of Drawings & Model
8. Samples
9. Material Tests & Mix Designs
10. Consultant and Contractor
11. Consultant's Decisions
12. Superintendence
13. Materials, Appliances, Employees
14. Inspection of Work
15. Rejected Work
16. Deductions of Uncorrected Work
17. Correction after Completion
18. Emergencies
19. Protection of Work & Property
20. Contractors' Insurance
21. Performance bond
22. Cash Allowance
23. Sub-surface Conditions
24. Changes in the Work
25. Valuation of Changes
26. Application for Payments
27. Certificates & Payments
28. Taxes
29. Permits, Notices. Laws & Rules
30. Patent Fees
31. Use of Premises
32. Cleaning Up
33. Cutting, Patching & Digging
34. Delays
35. Owner's Right to do Work
36. Owner's Right to Terminate Contract
37. Contractor's Right to Suspend Work or Terminate contract
38. Damages & Mutual Responsibility
39. Separate Contracts with Other Contractors
40. Assignment
41. Subcontracts
42. Relations of Contractor and Sub-Contractor
43. Arbitration
44. Owner Signing Authority
45. Conflict of Interest

1. DEFINITIONS

- a) The Contract Documents shall include instructions to Tenderers, General Conditions, Supplementary General Conditions, Specifications, Drawings, Tender Form and the signed agreement.
- b) The Owner, the Contractor and the Consultant are those names as such in the Agreement and Specifications.
- c) The term 'Subcontractor' includes only a person, firm or corporation having a contract for the execution of a part or parts of the work included in the Contract, and a person, firm or corporation furnishing material called for in the Contract and worked to a special design according to the Drawings or Specifications, but does not include one who merely furnishes material not so worked.
- d) The term 'work' includes all labour, materials and services required, as shown or described in the contract, documents, supplied and installed or erected complete at the place of building.
- e) The term 'Other Contractor' means any person, firm or corporation employed by or having a contract directly or indirectly with the Owner otherwise than through the Contractor.
- f) The place of building is the designated site or location of the completed work.
- g) The law of the place of building shall govern the work.
- h) For the purpose of contract signing authority, the Director is the Director of the Public Works and Planning Division of the PEI Department of Transportation and Infrastructure.

2. DOCUMENTS

- a) The Contract Documents shall be signed in duplicate by the Owner and Contractor. The Contract Documents are complementary and what is called for by any one shall be as binding as if call for by all. The intention of the documents is to include all labour and materials reasonably necessary for the proper execution of the work. It is not intended however, that materials or work not covered by or properly inferable from any heading, section or trade in the specifications shall be supplied unless shown on the drawings. Descriptions of materials or work in words which so applied have well known technical or trade meanings shall be held to refer to such recognized standards. Should the specification conflict with the drawings, the specifications shall govern. In the case of discrepancies between drawings, those of larger scale, or if the scales are the same, those of later date shall govern.

All drawings and specifications shall be interpreted in conformity with the agreement and these General Conditions which shall govern.

3. DETAIL DRAWINGS & INSTRUCTIONS

- a) The Consultant shall furnish as necessary for the execution of the work, additional instructions, by means of drawings or otherwise. All such additional instructions shall be consistent with the Contract Documents. The work shall be executed in conformity therewith and the Contractor shall do no work without such additional instructions. In giving such additional instructions, the Consultant shall have authority to make minor changes in the work, not inconsistent with the Contract.

If either the Contractor or the Consultant so request, they shall jointly prepare a schedule, subject to change from time to time in accordance with the progress of the work fixing the dates at which the various detail drawings will be required and the Consultant shall furnish them in accordance with this schedule, and on like request, a schedule shall be prepared, fixing the dates for the submission of shop drawings, for the beginning of manufacture and installation of materials and for the completion of the various parts of the work.

4. COPIES FURNISHED

- a) The Consultant shall furnish to the Contractor, without charge, as many copies of all Drawings and Specifications as are reasonably necessary for the proper execution of the work.

5. SHOP DRAWINGS

- a) The Contractor shall furnish to the Consultant, at proper times, all shop and setting drawings or diagrams which the Consultant may deem necessary in order to clarify the details of the work. The Contractor shall make any changes in such drawings or diagrams which the Consultant may require consistent with the Contract, and shall submit sufficient copies of the revised prints to the Consultant for approval – all but one of which shall be returned to the Contractor if approved by the Consultant. When submitting such shop and setting drawings, the Contractor shall notify the Consultant in writing of changes made therein from the Consultant's Drawings or Specification. The Consultant's approval of such drawings or of the revised drawings shall not relieve the Contractor from responsibility for errors made by the Contractor therein or for changes made from the Consultant's Drawings or Specifications not covered by the Contractor's written notification to the Consultant.

6. DRAWINGS AND SPECIFICATIONS ON THE WORK

- a) The Contractor shall keep one copy of all Drawings, Specifications and approved shop drawing on the work, in good order, available to the Consultant and to his or her representatives.

7. OWNERSHIP OF DRAWINGS AND MODELS

- a) All drawings, specifications and copies thereof and all models furnished by the Consultant are property of the Owner. They are not to be used on other work and, with the exception of the signed contract set of the Drawings and Specifications, are to be returned to him or her on request on the completion of the work. Any models furnished by the Contractor or the Owner are the property of the Owner.

8. SAMPLES

- a) The Contractor shall furnish for the Consultant's approval such samples as he or she may reasonably require. The work shall be in accordance with approved samples.

9. MATERIAL TESTS AND MIX DESIGNS

- a) The Contractor shall furnish for the Consultant's approval such material tests and mix designs as he or she may reasonably require. The cost of providing the foregoing beyond the extent called for in the specification shall be charged to the Owner. The work shall be in accordance with approved material tests and mix designs.

10. CONSULTANT AND CONTRACTOR

- a) The Consultant is, in the first instance, the interpreter of the Contract and the judge of its performance; he or she shall use his or her powers under the Contract to enforce its faithful performance by both parties hereto. The Contractor shall, however, have complete control, subject to Article 12, of his or her organization. In case of the termination of the employment of the Consultant, the Owner shall appoint any Consultant whose status under the Contract shall be that of the former Consultant.

11. THE CONSULTANT'S DECISION

- a) The Consultant shall decide on questions arising under the Contract Documents, whether as to the performance of the work or the interpretation of the Specifications and drawings, but should the Contractor hold such decisions to be at variance with the Contract Documents or to involve changes in the work already built, fixed, ordered or in hand in excess of the contract, or to be given in error, he or she shall notify the Consultant before proceeding to carry them out. In the event of the Consultant and the Contractor failing to agree as to such excess or error and the Consultant deciding to carry out such disputed work, the Contractor shall act according to such decision. Any question of excess of cost due to the aforesaid cause may be decided in the manner hereinafter provided in Article 43.

12. SUPERINTENDENCE

- a) The Contractor shall keep on the work, during its progress, a competent superintendent and any necessary assistants, all satisfactory to the Consultant. The superintendent shall not be changed except with the consent of the Consultant, unless the superintendent proves to be unsatisfactory to the Contractor or ceases to be in his or her employ. The superintendent shall represent the Contractor in his or her absence and directions on minor matters given to him or her shall be held to be given to the Contractor. Important directions shall be given in writing to the Contractor. The Contractor shall give efficient supervision to the work using his or her best skill and attention.

13. MATERIALS, APPLIANCES, EMPLOYEES

- a) Unless otherwise stipulated, the Contractor shall provide and pay for all materials, labour, water, tools, equipment, light and power necessary for the execution of the work. Unless otherwise specified all materials shall be new. Both workmanship and materials shall be of the quality specified. The Contractor shall not employ on the work any unfit person or anyone not skilled in the work assigned to him or her.

14. INSPECTION OF WORK

- a) The Owner, or the Consultant on his or her behalf, and their representatives shall at all times have access to the work wherever it is in preparation or progress and the Contractor shall provide proper facilities for such access and for inspection. If the specifications, the Consultant's instructions, the laws, or the ordinances of any public authority require any work to be specially tested or approved, the Contractor shall give the Consultant timely notice of its readiness for inspection, and if the inspection is by an authority other than the Consultant, of the date and time fixed for such inspection. Inspections by the Consultant shall be promptly made. If any such work should be covered up without approval or consent of the Consultant, it must, if required by the Consultant, be uncovered for examination and made good at the Contractor's expense. Re-examination of questioned work may be ordered by the Consultant. If such work be found in accordance with the Contract, the Owner shall pay the cost of re-examination and replacement. If such work be found not in accordance with the contract, through the fault of the Contractor, the Contractor shall pay such cost.

15. REJECTED WORK

- a) The Contractor shall promptly remove from the premises any defective work, whether the result of poor workmanship, use of defective materials, damage through carelessness or other act of the Contractor, which has been condemned by the Consultant as failing to conform to the Contract Documents, whether incorporated in the work or not. The Contractor shall

promptly replace and re-execute his or her own work in accordance with the contract and without expense to the Owner and shall bear the expense of making good all work of other Contractors destroyed or damaged by such removal or replacement. If the Contractor does not remove such condemned material or work within the time fixed by written notice, the Owner may remove them and may store such materials at the expense of the Contractor. If the Contractor does not pay the expense of such removal within Five (5) days thereafter, the Owner may, upon Ten (10) day's written notice, sell such materials at auction or at private sale and shall account for the net proceeds thereof, after deducting all the costs and expenses that should have been borne by the Contractor.

16. DEDUCTIONS FOR UNCORRECTED WORK

- a) If, in the opinion of the Consultant, it is not expedient to correct defective work or work not done in accordance with the Contract Documents, the Owner may deduct from the contract price the difference in value between the work as done and that called for by the contract, the amount of which shall be determined in the final instance by the Consultant.

17. CORRECTION AFTER COMPLETION

- a) Subject to any special provisions in the Contract Documents, the Contractor shall remedy any defects due to faulty materials or workmanship appearing within a period of one year from the date of substantial completion of the work and shall pay for any damage to other work resulting therefrom which appears within such period and neither the final certificate nor payment thereunder shall relieve the Contractor from responsibility hereunder. The Owner shall give notice of observed defects promptly. Questions arising under this Article may be decided as provided in Article 43.

18. EMERGENCIES

- a) The Consultant has authority in an emergency to stop the progress of the work whenever, in his or her opinion, such stoppage may be necessary to ensure the safety of life, or of the structure, or neighbouring property. This includes authority to make such changes and to order, access and award the cost of such work extra to the Contract or otherwise as may in his or her opinion be necessary.

19. PROTECTION OF WORK AND PROPERTY

- a) The Contractor shall maintain continuously adequate protection of all his or her work from damage and shall take reasonable precautions to protect the Owner's property from all injury arising in connection with this Contract. He or she shall make good any damage or injury to his or her work and shall make good any damage or injury to the property of the Owner resulting from the lack of reasonable protective precautions. He or she shall not be responsible,

however, for any damage or injury to his or her work and to the property of the Owner which may be directly due to errors in the Contract Documents or caused by the Owner, his or her agents, or employees, or from any work or risk which the Owner has agreed to insure, provided the Contractor has taken reasonable protective precautions. He or she shall adequately protect adjacent property as required by law and the Contract Documents.

20. CONTRACTORS' INSURANCE

a) INDEMNITY/HOLD HARMLESS

- .1 The Contractor shall be liable for all injuries to persons and for damage to property caused by his or her operations, and those of his or her sub-contractors, and his or her and their employees, engaged on all operations in connection with the contract both on and off the site, and he or she shall indemnify and save harmless the Owner from all suits, claims, expenses, costs, demands, losses, and damages to which the Owner may be put by reason of injury, including death, to persons, and damage to property of the Owner and others, resulting from; negligence, carelessness and any other cause whatsoever in the performance of the work.
- .2 The Contractor shall, until the date of issue of the final Certificate of Approval of the work by the Consultant, Indemnify and Save Harmless the Owner, and protect his or her own interests against:
 - (a) Theft, burglary or robbery of, and loss or damage to, all materials and equipment brought to the site for use in the work, whether or not such materials and equipment are incorporated in the work at the time that any such theft, burglary, robbery, loss or damage occurs.
 - (b) Theft or burglary of, and loss or damage to, any of his or her own plant and equipment being used on the Project and/or stored on the site.

b) BUILDERS RISK, ALL RISK PROPERTY INSURANCE

- .1 The Contractor shall, without limiting its obligations or liabilities herein and at its own expense, provide and maintain the following insurances with Insurers and in forms and amounts acceptable to Government:
 - (a) The Contractor shall have Commercial General Liability coverage in an amount not less than Two Million (\$2,000,000.00) dollars inclusive per occurrence against bodily injury and property damage. **The Government of Prince Edward Island is to be added as an additional insured under this policy.** Such insurance shall include, but not be limited to:

- i) Blanket Written Contractual Liability;
- ii) Personal Injury Liability;
- iii) Non-owned Automobile Liability;
- iv) Cross Liability;
- v) Operation of Attached Machinery

Commercial General Liability insurance shall be endorsed to provide the Owner with thirty (30) day advance written notice of cancellation or material change and fifteen (15) days notice in the event of non-payment.

- (b) Automotive liability coverage (Standard Automobile Policy) on all vehicles, the subject of this Agreement, owned, leased, operated or licensed in the name of the Contractor, in an amount not less than Two Million (\$2,000,000.00) dollars
- (c) If the work involves new construction or reconstruction of a property being repaired or maintained, the Contractor shall provide and maintain All Risk Course of Construction (Builder's Risk) to the full value of the work in the amount of the Contract Price. The policy will permit partial or complete use or occupancy by the Owner during the term of this insurance.

All the foregoing insurance shall be primary and not require the sharing of any loss by any insurer of the Government nor by any other form of recovery available such as the Provincial Self Insurance and Risk management Fund.

.2 Proof of Insurance

A Certificate(s) of Insurance and any renewals thereof, shall be furnished to the Government prior to commencement of work by the Contractor and must be updated as required during the Term.

The policies required by this Agreement shall be in a form and with insurers satisfactory to the Government. Default of deliver or receipt by the government shall not be construed as acknowledgement or concurrence that there has been compliance with the terms of this Agreement.

.3 Indemnification

The Contractor shall indemnify and hold harmless the Government of Prince Edward Island, its agents, representatives and employees from and against all claims, demands, losses, costs, damages, actions, suits or proceedings of every nature and kind whatsoever arising out of or resulting from the performance of work (herein called the "claims"), provided that any such claim is caused in whole or in part of any act, error or omission, including but not

limited to those of negligence of the Contractor, or anyone directly or indirectly employed by the Contractor anyone for whom the Contractor may be liable.

21. PERFORMANCE BOND

- a) The Owner shall have the right to require the Contractor to furnish a bond covering the faithful performance of the Contract – including the corrections after completion provided for in Article 17 – and the payment of all obligations arising under the contract, in such form as the Consultant may prescribe and with such sureties as he or she may approve. If such bond is required by written instructions given previous to the receipt of bids, the premium shall be paid by the Contractor, if subsequent thereto, it shall be paid by the Owner.

22. CASH ALLOWANCES

- a) The Contractor shall include in the contract sum all cash allowances mentioned in the Specifications, which allowances shall be expended in whole or in part as the Consultant shall direct and the amount of the contract sum being adjusted in conformity therewith. The Contract sum includes such sums for expenses and profit on account of such cash allowances as the Contractor requires except those allowances included for contingency purposes.

23. SUBSURFACE CONDITIONS

- a) In the event that during the execution of the work, subsurface conditions at the site are found to differ materially from those indicated in the Contract Documents and soil reports, or otherwise represented by the Owner or Consultant to the Contractor, then the Contractor shall promptly notify the Consultant in writing of such conditions, the Consultant shall promptly investigate such conditions and if he or she finds that they differ materially and will result in an increase or decrease in the cost of, or time required for performance of this Contract, an equitable adjustment shall be made between the parties and the contract modified in writing accordingly. If the parties fail to agree upon the adjustment to be made, the dispute may be determined as provided for in Article 43.

24. CHANGES IN THE WORK

- a) The Owner or the Consultant, without invalidating the contract, may make changes by altering, adding to, or deducting from the work, the contracts sum being adjusted accordingly. All such work shall be executed under the conditions of the Contract except that any claim for extension or reduction of time caused thereby shall be adjusted at the time of ordering such change. Except as provided in Article 18, no change shall be made unless in pursuance of a written order from the Consultant and no claim for an addition to or deduction from the contract sum shall be valid unless so ordered and at the same time valued, or agreed to be valued, as provided in Article 25.

25. VALUATION OF CHANGES

- a) Change Orders calling for normal changes or additions to the work will be priced in detail giving actual material trade prices (not list prices) and actual labour costs (including Employment Insurance, Worker's Compensation, holiday pay) and actual equipment rental. To these prices the Contractor will add:
- .1 For work less than \$2,500 involving the General Contractor only, the General Contractor adds 20% to his or her costs.
 - .2 For work over \$2,500 involving the General Contractor only, the General Contractor adds 15% to his or her costs.
 - .3 For work less than \$2,500 involving a Sub-Contractor only, the Sub-Contractor adds 20% to his or her costs, submits this price to the General Contractor who adds 10%.
 - .4 For work over \$2,500 involving a Sub-Contractor only, the Sub-Contractor adds 15% to his or her cost, submits this price to the General Contractor who adds 5%.
 - .5
 - (a) For work less than \$2,500 involving the General Contractor and Sub-Contractor, the Sub-Contractor adds 20% to his or her costs, submits his or her price to the General Contractor who adds 10%; to this amount the General Contractor adds the cost of his or her own work plus 20% of the cost of his or her own work only.
 - (b) The General Contractor does not add a further 10% to the cost of his or her own work.
 - .6
 - (a) For work over \$2,500 involving the General Contractor and a Sub-Contractor, the Sub-Contractor adds 15% to his or her cost, submits this price to the General Contractor who adds 5%; to this amount the General Contractor adds the cost of his or her own work plus 15% of the cost of his or her own work only.
 - (b) The General Contractor does not add a further 5% to the cost of his or her own work.
 - .7 Deletions to Contract: A mark-up shall **not** be charged nor credited on a credit portion of a Change Order.
 - .8 Supervision related to Change Orders shall be considered as included in the allowable mark-up and shall **not** be included in the labour charges for a Change Order.

26. APPLICATION FOR PAYMENTS

- a) The Contractor shall – before the first application for payment – submit to the Consultant a schedule of values of the various parts of the work aggregating to the total sum of the contract, divided so as to facilitate payments, made out in such form, and supported by such evidence as to its correctness as the Consultant may direct. This schedule, when approved by the Consultant, shall be used as a basis for applications of payment, unless it can be found to be in error.
- b) The Contractor, as per current Provincial regulation, shall include on all invoices the Harmonized Sales Tax as an additional line item. This amount would be in addition to the tender amount which does not include HST. See article 28 of this Section.

27. CERTIFICATES AND PAYMENTS

- a) Partial payments will be made monthly and within thirty (30) days after approval by the Owner and on the basis of a duly certified and approved estimate of work performed during the preceding period. In preparing estimates, the material delivered on the site and preparatory work done shall be taken into consideration.
- b) In making such partial payments, there shall be retained a hold back in the amount of fifteen percent (15%) of the estimated amount on each partial payment estimate, less any holdback release which may have been made to specific sub-contractors under any progressive release of holdback provisions in Provincial Legislation.
- c) All materials and work covered by partial payments made shall thereupon become the sole property of the Owner, but this shall not be construed as relieving the Contractor from the sole responsibility for the safety and preservation of all materials and work upon which payments have been made and restoration of any damaged work or as a waiver of the right of the Owner to require the fulfillment of all the terms of the contract. Nor shall Consultant's Certification of Partial Payment for any work be construed as his or her final or irrevocable acceptance of that work.
- d) Document of Completion: Upon completion and acceptance of all work whatsoever required and the release of all claims against the Owner as specified, the Consultant shall file a written document with the Owner and with the Contractor as to the entire amount of work performed and compensation earned by the Contractor – including the extra work and compensation therefore.
- e) Final Payment: Within sixty (60) days after the filing of such document of completion and minimum one (1_ day after the lien period, and upon receipt from the General Contractor of declarations signed by each of his sub-contractors that the sub-contractor has been paid up to,

and including the past previous partial payment, the Owner will pay the Contractor the amount stated therein less all deductions authorized by the terms of this contract and previous payments and advances whatsoever to or for the account of the Contractor. All previous estimates and payments, including those relating to extra work, shall be subject to correction at the time of this payment which is, throughout this contract, called Final Payment. Final Payment shall be subject to inspection and acceptance by the Owner or duly authorized representatives of the Owner and by representatives of all agencies having direct interest in the project.

Submittals to include:

- Certificate or letter of clearance from the Provincial Worker's Compensation Board
- f) With the second and all subsequent applications for payment, the Contractor shall include a statutory declaration form CCDC 9B, or other similar acceptable form to the Owner, declaring that all labour and materials entering into the work, including Sub-Contractors, covered by the previous application, have been paid. With application for release of lien holdback, the Contractor shall include a statutory declaration form CCDC 9A, or other similar form acceptable to the Owner.
- g) With application for release of lien holdback, the Contractor shall include certificates issued by the Worker's Compensation Board, indicating that Worker's Compensation premiums in relation to the project have been paid in full.

28. TAXES

- a) Unless otherwise provided herein, the Contractor shall pay all government sales or excise taxes in force at the date of the Agreement, provided that any increase or decrease in such taxes shall increase or decrease the contract sum accordingly.

29. PERMITS, NOTICES, LAWS AND RULES

- a) The Contractor shall apply and pay for all necessary permits or licenses required for the execution of the work (but this shall not include the obtaining of the Building Permit or permanent easement or right of servitude). The Contractor shall give all necessary notices and pay all fees required by law and comply with all laws, ordinances, rules and regulations relating to the work and to the preservation of the public's health. The Contractor shall be responsible for the safety of all workmen and equipment on the project in accordance with all applicable safety legislation passed by federal, provincial and local authorities governing construction safety.

If the Contract Documents are at variance therewith, any resulting additional expense incurred by the Contractor shall constitute an addition to the contract price.

30. PATENT FEES

- a) The Contractor shall pay all royalties and license fees and shall save the Owner harmless from loss on account of suits or claims for infringement of patents in the doing of the work.

31. USE OF PREMISES

- a) The Contractor shall confine his or her apparatus, the storage of materials and the operations of his or her workmen to limits indicated by laws, ordinances, permits or by direction of the Consultant and shall not unreasonably encumber the premises with his or her materials. The Contractor shall not load – or permit to be loaded – any part of the work with a weight that will endanger its safety. The Contractor shall enforce the Consultant’s instructions regarding signs, advertisements, fires and smoking.

32. CLEANING UP

- a) The Contractor shall at all times keep the premises free from accumulations of waste material or rubbish caused by his or her employees or work and, at the completion of the work, he or she shall remove all his or her rubbish and all tools, equipment and surplus materials from and about the work and shall leave the work “broom clean” or its equivalent, unless more exactly specified. In case of dispute, the Owner may remove the rubbish and charge the cost as the Consultant shall determine to be just.

33. CUTTING, PATCHING AND DIGGING

- a) The Contractor shall do all cutting, fitting or patching of his or her work that may be required to make its several parts come together properly and fit it to receive or be received by work of Other Contractors shown upon, or reasonably implied by, the Contract Documents.

Any cost caused by ill-times work shall be borne by the party responsible, therefore.

The Contractor shall not endanger any existing work by cutting, digging or otherwise and shall not cut or alter the work of any other Contractor save with the consent of the Consultant.

34. DELAYS

- a) If the Contractor is delayed in the completion of the work by any act or neglect of the Owner, Consultant or any Other Contractor or any employee of any one of them or by changes ordered

in the work, then the time of completion shall be extended for such reasonable time as the Consultant may decide.

- b) If the Contractor is delayed in the performance of the Work by:
- .1 labor disputes, strikes, lock-outs (including lock-outs decreed or recommended for its members by a recognized contractors' association, of which the Contractor is a member or to which the Contractor is otherwise bound),
 - .2 fire, unusual delay by common carriers or unavoidable casualties,
 - .3 abnormally adverse weather conditions, or any cause beyond the Contractor's control other than one resulting from a default or breach of Contract by the Contractor the Contractor will make reasonable efforts to counter the circumstances giving rise to the delay or to otherwise remedy its inability to perform its obligations by utilizing all resources reasonably required in the circumstances, including obtaining supplies or services from other sources if the same are reasonably available (including seeking injunctive relief or other judicial, quasi-judicial or law enforcement remedy, provided that the Contractor will not be required to settle or resolve any labor disturbance, strike, lock-out, or work slowdown (collectively "Employment Matters") but excluding any Employment Matters involving persons retained, employed or hired by the Contractor to supply materials or services to meet the Contractor's obligations under this Contract; or any Employment Matter caused by, or attributable to, any act (including any pricing or other practice or method of operation) or omission of the Contractor. Only after the Contractor has made such reasonable efforts the Contract Time shall be extended for such reasonable time as the Consultant may recommend in consultation with the Contractor. The extension of time shall not be less than the time lost as the result of the event causing the delay, unless the Contractor agrees to a shorter extension. The Contractor shall not be entitled to payment for costs incurred by such reasonable efforts or delays unless such reasonable efforts or delays were required as a result of actions by the Owner, Consultant or anyone employed or engaged by them directly or shall be necessary.

No such extension shall be made for delay unless written notice of claim is given to the Consultant within seven (7) days of its commencement provided, however, that in the case of a continuing cause of delay only one claim shall be necessary.

If no schedule is made under Article 3, no claim for delay shall be allowed on account of failure to furnish drawings until two (2) weeks after demand for such drawings and not then unless such claim be reasonable.

The Consultant shall not, except by written notice to the Contractor, or as provided in Article 18, stop or delay any part of the work pending decisions or proposed changes either by him or herself or by the Owner.

35. OWNER'S RIGHT TO DO WORK

- a) If the Contractor should neglect to execute the work properly or fail to perform any provision of this Contract, the Owner, after five (5) days written notice to the Contractor, may without prejudice to any other right or remedy he or she may have, make good such deficiencies and may deduct the cost thereof from the payment then or thereafter due the Contractor; provided however, that the Consultant shall approve both such actions and the amount charged to the Contractor.

36. OWNER'S RIGHT TO TERMINATE CONTRACT

- a) If the Contractor should be adjusted as bankrupt, or if he or she should make a general assignment for the benefit of his or her creditors, or if a receiver should be appointed on account of his or her insolvency or if he or she should – except in case of recited in Article 35 – refuse or fail to supply enough properly skilled workmen or proper materials after having received seven (7) days notice in writing from the Consultant to supply additional workmen or materials, or if he or she should fail to make prompt payment to Sub-Contractors or for material or labour, or persistently disregard laws, ordinances or the instruction of the Consultant, or otherwise be guilty of a substantial violation of the provisions of the Contract, then the Owner, upon the certificate of the Consultant that sufficient cause exists to justify such action, may, without prejudice to any right or remedy he or she may have, by giving the Contractor written notice, terminate the employment of the Contractor and take possession of the premises and of all materials, tools and appliances thereon and finish the work by whatever method he or she may deem expedient, but without undue delay or expense. In such case, the Contractor shall not be entitled to receive the expense of finishing the work, including compensation to the Consultant for his or her additional services; such excess shall be paid to the Contractor. If such expense shall exceed such unpaid balance, the Contractor shall pay the difference to the Owner. The expense incurred by the Owner as herein provided, shall be certified by the Consultant.

37. CONTRACTOR'S RIGHT TO SUSPEND WORK OR TERMINATE CONTRACT

- a) If the work should be stopped under an order of any court or other public authority through no act or fault of the Contractor or of anyone employed by him or her, or if the Consultant fails to issue a certificate in accordance with Article 27, or if the Owner should fail to pay to the Contractor within seven (7) days of its maturing and presentation, any sum certified by the Consultant or awarded by arbitrators, then the Contractor may, upon five (5) days written notice to the Owner and the Consultant, stop work and/or terminate this Contract without

prejudice to any other right or remedy he or she may have and recover from the Owner payment for all work executed and any loss sustained upon the plant or material with reasonable profit and damages.

38. DAMAGES AND MUTUAL RESPONSIBILITY

- a) If either party to this Contract should suffer damage in any manner because of any wrongful act or neglect of the other party or of anyone employed by him or her then he or she shall be reimbursed by the other party for such damage. Claims under this paragraph shall be made in writing to the party liable within a reasonable time after the first observance of such damage and not later than the time of final certificate, except as expressly stipulated otherwise in the case of faulty work or materials, and may be adjusted by agreement or in the manner set out in Article 43 and the party reimbursing the other party as aforesaid shall thereupon be subrogated to the rights of the other party in respect of such wrongful act or neglect if it be that of a third party. Should the Contractor cause damage to any other Contractor on the work the Contractor agrees – upon due notice – to settle with such other Contractor by agreement or arbitration, if he or she will so settle. If such other Contractor sues the Owner on account of any damage alleged to have been so sustained, the Owner shall notify the Contractor who shall defend such proceedings at the Owner's expense and if any final order or judgment against the Owner arises therefrom the Contractor shall pay or satisfy it and pay all costs incurred by the Owner provided that if the Contractor becomes liable to pay or satisfy any final order or judgment against the Owner, then the Contractor shall have the right upon undertaking to indemnify the Owner against any and all liability for costs to appeal, in the name of the Owner, such final order or judgment to any and all courts or competent jurisdiction.

39. SEPARATE CONTRACTS WITH OTHER CONTRACTORS

- a) The Owner reserves the right to let separate contracts in connection with the undertaking of which the work is a part and the Contractor shall connect properly and coordinate this work with that of other Contractors. If any part of the Contractor's work depends – for its proper execution or results – upon the work of any other Contractor, the Contractor shall inspect the work prior to proceeding with his or her work as required by the Contract. Should the Contractor fail so to inspect and report, he or she shall have no claim against the Owner by reason of the defective or unfinished work of any other Contractor except as to latent defects not reasonably noticeable at the time of the commencement of the Contractor's work. In letting separate contracts, the Owner shall be responsible for the coordination of fire and other insurance coverages and shall take all precautions reasonable possible to avoid possible occurrence of a labour dispute or disputes on the work.

40. ASSIGNMENT

- a) Neither party to the Contract shall assign the Contract without the written consent of the other.

41. SUB-CONTRACTS

- a) The Contractor agrees that the list of names of sub-contractors supplied prior to the signing of the Contract is the list of Sub-Contractors proposed to be used to carry out those parts of the work noted thereon and he or she shall not employ any to whom the Consultant may reasonably object.

If the change of any name on such list is required by the Consultant and the work has to be awarded to a higher bidder, the contract price shall be increased by the difference between the two bids.

The Consultant shall, on request, furnish to any Sub-Contractor wherever practicable, evidence of the amounts certified to on his or her account.

The Contractor shall be held as fully responsible to the Owner for the acts and omissions of his or her sub-contractors and of persons directly or indirectly employed by them, as for the acts and omissions of persons directly employed by him or her. In view of this responsibility, the Contractor shall not be obliged to employ as a sub-contractor or supplier any person or firm to whom he or she may reasonably object.

42. RELATIONS OF CONTRACTOR AND SUB-CONTRACTOR

- a) The Contractor agrees to bind every sub-contractor by the terms of the Contract Documents, as far as applicable to his or her work.

43. ARBITRATION

- a) In the case of any dispute arising between the Owner (or the Consultant acting on his or her behalf) and the Contractor as to their respective rights and obligations under the Contract, either party hereto shall be entitled to give to the other notice of such dispute and to request arbitration thereof; and the parties may, with respect to the particular matters then in dispute, agree to submit the same to arbitration in accordance with the applicable law of the place of building.

Arbitration proceedings shall not take place until after the completion or alleged completion of the work except (a) on a question of certificate for payment, or (b) in a case where either party can show that the matter in dispute is of such nature as to require immediate consideration while evidence is available.

44. OWNER SIGNING AUTHORITY

- a) Mr. Adam Clark, P. Eng. is designated as the Director for the purposes of this agreement, the Director shall represent Government in all matters pertaining to the construction project being

provided pursuant to this agreement, and will administer said agreement, and shall complete necessary approvals of all plans and specifications provided for under this agreement on behalf of Government, provided however, that the Director shall not be authorized to amend the terms of the Agreement.

Government may replace the Director by providing written notice, in accordance with the notice requirements of this Agreement.

45. CONFLICT OF INTEREST

- a) The Contractor warrants that as at the date of this Agreement, no conflict of interest, or any circumstance that might interfere with independent and objective exercise of judgment, exists or is likely to arise in relation to execution of this Agreement or its subject matter. The Contractor shall immediately notify Government, in writing, if any such actual or potential conflict of interest should arise at any time during the Term. In the event Government discovers or is notified by the Contractor of an actual or potential conflict of interest, Government, in its sole discretion, may either:
 - i) allow the Contractor to resolve the actual or potential conflict to the satisfaction of Government; or
 - ii) terminate the Agreement in accordance with the Termination section of this Agreement.

END

PROJECT:

1. GENERAL

- a) The undersigned tenderer (hereinafter called the “Contractor”) hereby offers to the Minister of Transportation and Infrastructure (hereinafter called the “Owner”) to furnish all necessary tools, plant, services, materials and labour to execute and complete in a careful and workmanlike manner the work set out under the **Project # 709-22065** herein, which is more particularly described in the Plans and Specifications titled **EV School Bus Charger Residential Installations - Queens County – Various Locations** and dated **August, 2023** for the lump sum as set out in Clause 3.

The Contractor agrees:

- .1 To complete the work by the date indicated on the Instructions to Bidders.
- .2 That this Form of Agreement supersedes and cancels all communication, negotiations and agreements relating to the work other than contained in the completed tender.
- .3 To use all suppliers and sub-contractors indicated on his or her tender unless prior approval is received from the Engineer to make a change.

2. ADDENDA

- a) The following addenda are included in this contract:

3. CONTRACT PRICE

- a) The Contract Price (*the lump sum referred to in Clause 1:*) which excludes value added taxes is:

- b) Value added (HST)(of _____%) payable by the Owner to the Contractor are:

- c) Total amount payable by the Owner to the Contractor for the construction of the work is:

4. CORRESPONDENCE

- a) The Owner, Consultant, and Contractor may be contacted in writing at the addresses below:

Owner & Consultant

PEI Department of Transportation and Infrastructure
PO Box 2000
Charlottetown, PE
C1A 7N8

Contractor

5. CONTRACTOR'S ACCEPTANCE

- a) Accepted and executed on behalf of the Contractor this ____ day of _____, 20____, in the presence of _____.

Witness

Signature & Corporate Seal

6. OWNER'S ACCEPTANCE

- a) Accepted and executed on behalf of the Owner this ____ day of _____, 20____, in the presence of _____.

Witness

Signature & Seal

END

1. GENERAL

1.1. TENDER

.1 SUBMITTED BY:

(Name) _____
(Address) _____
(Contact) _____
(Phone) _____ (Fax) _____
(Date) _____

FOR: Project
Project Address
Project Location

TO: Minister of Transportation and Infrastructure
11 Kent Street
PO Box 2000
Charlottetown, PE
C1A 7N8

HAVING examined the drawings and specifications for this project as well as any addenda issued, we hereby offer to furnish all materials, plant and labour necessary for the full and proper completion of:

“EV School Bus Charger Residential Installations – Queens County – Various Locations”

INCLUDING all prime cost allowances, or other taxes in force at this date and **excluding HST**; but not including any additional or deductible allowance or taxes which may be applicable subsequent to this date, and which shall be payable by or to the Owner, in accordance with the above mentioned documents, for the sum of:

_____ Dollars (\$ _____)
in lawful money of Canada.

In submitting this tender we recognize the necessity to complete the information requested on any appendices, as well as the right of the Owner to accept any tender at the price submitted or to reject all tenders, it being understood, and this tender is submitted on the condition that revised tenders will not be called for if minor changes are contemplated.

In the event of this tender being accepted within thirty (30) days of the time stated for the closing of tenders, and our failing or declining to enter into a contract, then our bid deposit shall be forfeited to the Owner in lieu of any damages which he or she may suffer by reason of our failure or refusal to enter into such contract.

In the event of our tender not being accepted within thirty (30) days of the time stated for the closing of tenders, the bid deposit will be returned to us forthwith unless a satisfactory arrangement is made with us covering its retention for a further stated period.

1.2. ACKNOWLEDGEMENT OF RECEIPT OF ADDENDA

.1 Addendum # _____ Issued _____ Initial _____
Addendum # _____ Issued _____ Initial _____
Addendum # _____ Issued _____ Initial _____
Addendum # _____ Issued _____ Initial _____
Addendum # _____ Issued _____ Initial _____

1.3. SUB-CONTRACTORS AND SUPPLIERS

.1 Our tender includes the following sub-contractors and suppliers, (own forces may be used, as per Section B item 12). The following work will be performed (or provided) by following Sub-contractors and supplies coordinated by us in our role as General Contractor.

Roof Membrane Manufacturer _____
Roofing Installer _____
Carpentry _____
Millwork _____
Doors / Hardware (Installation) _____
Flooring (Supplier) _____
Flooring (Installer) _____
Painting _____
Mechanical _____
Electrical _____

1.4. ACCEPTANCE OF AGREEMENT

- .1 If we are notified of the acceptance of this tender within the above specified time we will:
 - .1 Enter into a formal contract agreement with the Owners.
 - .2 Furnish a general analysis of the contract sum, the total aggregating the amount of our tender.
 - .3 Provide a Construction Schedule and complete the entire work on or before the dates stated.

1.5. LABOUR RATES

- .1 Prior to signing the Contract related to this Bid, the successful Bidder will provide the Owner with labor rates covering labor provided by the Bidder and major Subcontractors, for extra work carried out in relation to Change Order and Change Directive work. These labor rates are to be substantiated by actual labor costs and wage levies; the labor rates must be reasonable, in comparison to local industry standards, and acceptable to the Owner.

1.6. CONTRACTOR'S SIGNATURE

The undersigned bidder declares that this tender is made without connection with any other person or persons submitting tenders for the same work, and is in all respect, fair & without collusion or fraud.

- .1 Signed, sealed and submitted for and on behalf of:

Submitted by (Company Name)

Authorized Name and Title (Print)

Authorized Signature

Date

END

1. REFERENCES

- a) Canada Labour Code, Part 2, Canada Occupational Safety and Health Regulations.
- b) Health Canada/Workplace Hazardous Materials Information System (WHMIS).
 - .1 Material Safety Data Sheets (MSDS).
- c) Province of Prince Edward Island
 - .1 Occupational Health and Safety Act, R.S.P.E.I.1988 (including any amendments to and regulations)
- d) CSA C22.1-18 – Canadian Electrical Code, Part 1, Safety Standard for Electrical Installations.
- e) CSA C22.3 No. 7-94 (R2005) - Underground Systems
- f) COSH, Canada Occupational Health and Safety Regulations (SOR/86-304)
- g) Fire Protection Standards issued by Fire Protection Services of Human Resources Development Canada as follows:
 - .1 FCC No. 301 – June 1982 Standard for Construction Operations.(or latest edition)
 - .2 FCC No. 302 – June 1982 Standard for Welding and Cutting. (or latest edition)

2. COMPLIANCE REQUIREMENTS

- a) Comply with Occupational Health and Safety Act, Occupational Health and Safety Act Regulations PEI (including any amendments to and regulations).
- b) Comply with Canada Labour Code, Canada Occupational Safety and Health Regulations.
- c) Perform lockouts in compliance with:
 - .1 Canadian Electrical Code
 - .2 Federal and Provincial Occupational Health and Safety Acts and Regulations.
 - .3 Regulations and code of practice as applicable to mechanical equipment or other machinery being de-energized.

- d) In event of conflict between any provisions of above Authorities, the most stringent provision will apply. Should a dispute arise in determining the most stringent requirement, the Consultant will advise on the course of action to be followed.

3. CONSTRUCTION SAFETY MEASURES

- a) Observe and enforce construction safety measures required by latest National Building Code, Part 8, Provincial Government, Worker's Compensation Board and municipal statues and authorities.
- b) Provide and maintain first aid equipment appropriate to the work and its location in accordance with the First Aid Regulations. Implement recommendations from Occupational Health and Safety Division specific to the project work site.

4. HEALTH AND SAFETY COORDINATOR

- a) Employ and assign to work, competent and authorized representative as Health and Safety Coordinator. Health and Safety Coordinator must:
 - .1 Have minimum 2 years site-related working experience specific to activities associated with Construction.
 - .2 Having working knowledge of occupational health and safety regulations.
 - .3 Be responsible for completing Contractor's Health and Safety Training Sessions and ensuring that personnel not successfully completing required training are not permitted to enter site to perform work.
 - .4 Be responsible for implementing, enforcing daily and monitoring site-specific Contractor's Health and Safety Plan.

5. SAFETY ASSESSMENT

- a) Perform site specific hazard assessment related to project.
- b) Perform on-going hazard assessments during the progress of Work identifying new or potential health risks and safety hazards not previously known. As a minimum, hazard assessments shall be carried out when:
 - .1 New subtrade work, new subcontractor(s) or new workers arrive at the site to commence another portion of work.

- .2 The scope of work has been changed by Change Order.
- .3 Potential hazard or weakness in current health and safety practices are identified by Consultant or by an authorized safety representative.
- c) Each hazard assessment to be made in writing. Keep copies of all assessments on site for duration of Work. Upon request, make available to Consultant for inspection.

6. SUBMITTALS

- a) Upon request, submit within seven (7) days to the Consultant, one copy electronically and one hard copy of the site-specific Health and Safety Plan.
- b) Upon request, submit within seven (7) days to the Consultant, one copy electronically and one hard copy of the Contractor's authorized representative's worksite health and safety inspection reports.
- c) Upon request, submit within seven (7) days to the Consultant, one copy electronically and one hard copy of the construction safety tool box meetings and formal contractor safety meetings.
- d) In the event of an incident/accident, immediately submit to the Consultant one copy electronically and one hard copy of the incident/accident report.

7. SITE CONTROL AND ACCESS

- a) Control worksite and entry points. Grant and allow entry to only workers and other persons so authorized. Immediately stop non-authorized persons from circulating within construction areas and remove from site.
- b) Prior to gaining access to the site, all contractors, subcontractors and suppliers shall file with the General Contractor their proof of Workers Compensation coverage, proof of required Insurance and proof of contract. Upon request, proof of these documents will be provided to the Owner and Consultant.
- c) Delineate and isolate construction areas from other areas of site by use of appropriate means. Erect barricades, fences, hoarding and temporary lighting as required.
- d) Erect signage at entry points and at other strategic locations around site, clearly identifying construction areas(s) as being "off limits" to non-authorized persons. Signage must be professionally made.

- e) Ensure persons granted access is fitted and wear appropriate personal protective equipment (PPE).

8. PROTECTION

- a) Provide temporary facilities for protection and safe passage of building occupants, public pedestrian and vehicular traffic around and adjacent to work site.
- b) Provide safety barricades, lights and signage within work site as required to provide a safe working environment for workers.

9. MEETINGS

- a) Prior to commencement of work hold a Health and Safety meeting. Have Contractor's Site Superintendent in attendance.
- b) Provide site safety orientation session to all workers and all workers new to the site and other authorized persons prior to granting them access to work site. Brief persons on site conditions and on the site safety rules in force at site.
- c) Conduct site specific occupational health and safety meetings during the entire work as follows and submit minutes as requested.
 - .1 Formal meetings on a minimum monthly basis.
 - .2 Informal toolbox meetings on a regular basis from a predetermined schedule.
- d) Attend Health and Safety meetings as directed by the Contractor.

10. HAZARDOUS MATERIALS

- a) Should material resembling hazardous materials (other than those identified within the Contract Documents) be encountered in the course of work, stop work immediately. Do not proceed until written instructions have been received from the Consultant.
- b) Any material which contains asbestos, lead paint or PCB's that is disturbed or removed during construction work shall be removed in accordance with the regulations set out by the Occupational Health and Safety Act.

11. WHIMIS

- a) Comply with requirements of Workplace Hazardous Materials Information System (WHMIS) Regulations regarding use, handling, storage, and disposal of hazardous materials; and regarding labeling and provision of Safety Data Sheets.
- b) Have a copy of WHMIS Safety Data Sheets available at the workplace on delivery of hazardous products.

12. SITE CLEANING

- a) Except where special permission is obtained, maintain clean access on public sidewalks and roads.
- b) Maintain walks and roads clear of construction materials and debris, including excavated material. Clean walks and roads as frequently as required to ensure that they are cleared of materials, debris and excavated material.
- c) Remove snow and ice from areas as required to execute the work.

13. FIRE SAFETY REQUIREMENTS

- a) Comply with requirements of latest standard for Building Construction Operations issued by the Fire Commissioner of Canada and Fire Safety Regulations of Local Authority. (latest editions)
- b) Implement and follow fire safety measures during Work. Comply with following:
 - .1 National Fire Code, (latest edition)
 - .2 Fire Protection Standards FCC 301 and FCC 302, (latest edition).
 - .3 Federal and Provincial Occupational Health and Safety Acts and Regulations.
- c) In event of conflict between any provisions of above authorities the most stringent provision will apply. Should a dispute arise in determining the most stringent requirements, Consultant will advise on the course of action.
- d) Hot Work will not be permitted on or within the facility except as outlined herein. Prior to conducting hot work, a hot work permit (see attached Appendix B) shall be prepared and submitted. A new permit shall be obtained at the start of each work shift during which hot work will be conducted.

14. EMERGENCY MANAGEMENT PLAN

- a) Must include response for medical and fire emergencies.
- b) Know the location of the nearest fire alarm box and telephone (if no cell phone available), including the emergency phone number.
- c) Know where the “Civic Address” of worksite is posted to report to emergency personnel.
- d) Report immediately all fire incidents to the fire department as follows:
 - .1 Activate nearest fire alarm box
 - .2 Telephone 911
 - .3 Where fire alarm box is exterior to building, the person activating the fire alarm box shall remain at the box to direct Fire Department to scene of the fire.
 - .4 When reporting a fire by telephone, give location of fire, name or number of building and be prepared to verify the location.
- e) Notify the Owner of any emergency.

15. POSTING OF DOCUMENTS

- a) Ensure applicable items, articles, notices and orders are posted on site in accordance with Acts and Regulations of Province having jurisdiction, and in consultation with Consultant.

16. CORRECTION OF NON-COMPLIANCE

- a) Immediately address health and safety non-compliance issues identified by Authority having Jurisdiction or by Consultant.
- b) Provide Consultant with written report of action taken to correct non-compliance of health and safety issues identified.

17. OPEN EXCAVATIONS

- a) If open foundations or demolition areas are to be left at the end of a workday, a protective barrier must be placed around the entire perimeter of the open excavation or demolition areas to limit access by others. Barrier to be approved by the requirements established in the OH&S Regulations.

END

Appendix A - Special Instructions

EV School Bus Charger Residential Installations – Queens County – Various Locations

Tender Specifications – Include this page with your submittal

Supply and Install: As per photos in Appendix B

-100A single phase 120/240V underground service mounted on 3/4" pressure treated plywood mounted (top and two side edges to be protected by a non-corrosive (stainless steel, aluminum, or powder coated steel) metal frame (channel) with a minimum 25mm (1 inch) lip over the front and back of the plywood surface) on two 6x6 pressure treated posts (one 12' and one 16'. 5 ft to be buried with 150mm gravel for bedding). Posts must be capped to protect from water damage.

-100A 120/240V service rated outdoor panel

-Disconnect

-Wiring for 80A Electric Charger.

-Service ground

-20A Outdoor rated, duplex receptacle (non GFI)

-20-30watt (location dependent) LED Light, outdoor rated with dusk to dawn feature

-Trenching, back filling, cleanup and landscaping.

-Labor to install all equipment listed above, as well as the Clipper Creek CS100 80A charger (rated for 80A continuous, therefore requires 80A continuous breaker, and brand circuit to the charger must be copper wires only.), and the cable management system. **(the charger and the cable management system will be supplied by the owner - brochures in Appendix C).** The conduit leading to the light fixture must be offset to allow the installation of the cable management system on the 16' post.

Contractor to arrange with Public Schools Branch (PSB) and the Commission scolaire de langue française (CSLF) for the utility service order at each location.

-Electrical permit

Lump Sum (except for below) \$ _____ **A**

Cost per meter for supply/install underground service wire (lengths will vary depending on location) An assumed 25m will be used for this calculation for purpose of bidding. The actual length installed shall be used for payment.

25m x \$ _____ /m = \$ _____ **B**

9 locations x (\$ _____ **A** + \$ _____ **B**) = \$ _____ **C**

Amount C is the contract amount to be entered in sections D & E of the tender.

Note: This installation is planned to be installed in a way to be removed from one site and be used at another site if needed. Service would have to be disconnected by

Appendix A - Special Instructions

maritime electric. Service wires, conduit and service ground would have to be replaced.

Queens County EV Charger Locations

The successful contractor will have to meet onsite at the following locations with the bus driver and government representative to determine charger location.

75 Scully Lane, Donagh
1419 Bedford Rd, Route # 6, Grand Tracadie
6 Rosebank Road, Stratford
1573 Pownal Road, Alexandra
468 Line Road, Route 269, Hunter River
1476 Loyalist Road, Hampshire
1026 Bannockburn Road, Clyde River
1395 Inkerman Rd., Route 231, Breadalbane
661 Waterside Road, Mount Mellick

Appendix B - Photos



Appendix B - Photos

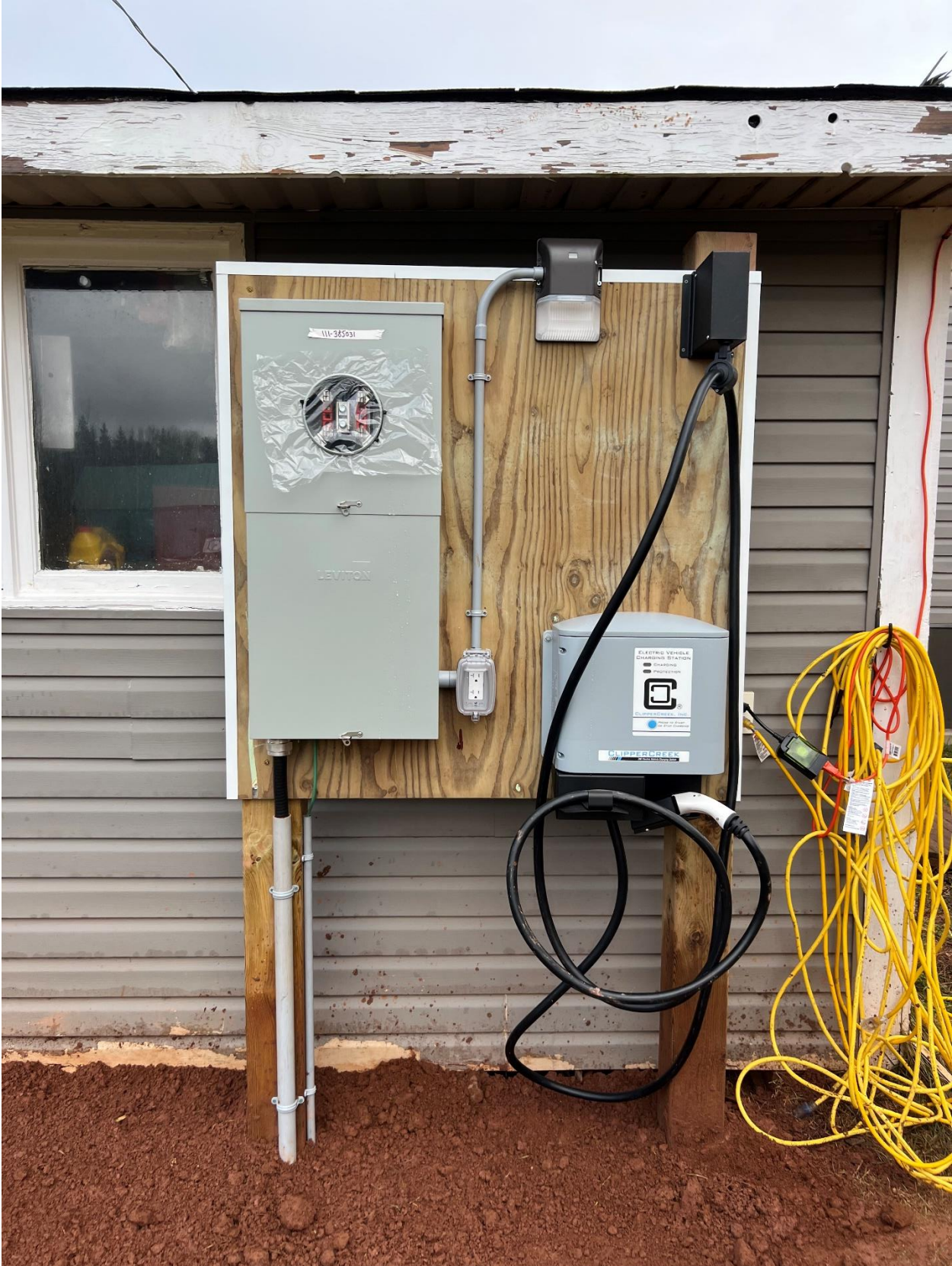

Appendix C - Product Brochures

CS-100 80A Continuous User Manual

Wall-Mounted Cable Management System – Installation Manual

CLIPPERCREEK, INC.
INNOVATIVE INFRASTRUCTURE FOR
ELECTRIC AND HYBRID VEHICLES



User Manual



Model CS-100
(programmed for 80A continuous)

PLEASE NOTE

This user manual includes the latest information at the time of printing. ClipperCreek, Inc. reserves the right to make changes to this product without further notice. Changes or modifications to this product by other than an authorized service facility may void the product warranty.

Contact a Customer Service Representative with any questions about the use of this product. (877) 694-4194

**To view the latest version of this manual please visit
clippercreek.com/installation-manuals**



WARNING: This product can expose you to chemicals, including Carbon Black, which is known to the State of California to cause cancer. For more information go to: www.P65Warnings.ca.gov

CONTENTS

IMPORTANT SAFETY INSTRUCTIONS	5
Instructions Pertaining to Risk of Fire or Electric Shock	6
ADDITIONAL SAFETY INFORMATION	8
FCC INFORMATION	9
OPERATION	10
Front Panel	11
In Case of Difficulty	12
FEATURES	13
Personnel Protection System	13
Ground Monitoring Circuit	13
Auto-Reclosure	13
Off-Peak Charging	13
Cold Load Pickup	14
External Error Indication	15
Maintenance Current	15
INSTALLATION - SERVICE CONNECTIONS	16
MOUNTING PROCEDURES	21
WIRING INSTRUCTIONS	23
Testing After Installation	24
FOR THE SERVICE TECHNICIAN	25
Diagnostic	25
Load Management Disable	25
GFCI Trip	25
Ground Missing	26
MAINTENANCE	27
SPECIFICATIONS	28
LOAD MANAGEMENT INPUTS	29
RELAY OUTPUT	30
CS CABLE WRAP GUIDELINES	31
CUSTOMER SUPPORT	32
WARRANTY INFORMATION	33

ILLUSTRATIONS

Figures

1. The CS-100 Front Panel.....	11
2. 220/240V Single Phase	18
3. 208V 3-Phase, Wye-Connected.....	19
4. 240V 3-Phase, Delta Connected w/Center Tap on One Leg.....	20
5. Wall Mounting of CS-100.....	21
6. CS-100 Installation Template.....	22
7. Front Door Hidden Latch	22
8. CS-100 Service Wiring.....	23
9. 4-Position Terminal Block.....	29
10. Wrap the Charge Cable Loosely.....	31

Tables

1. Front Panel Indicators	11
2. PC Board Diagnostic LEDs.....	26

IMPORTANT SAFETY INSTRUCTIONS

Carefully read these instructions and the charging instructions in your vehicle owner's handbook before charging an electric vehicle.

The following symbols may be found in this manual or on labels affixed to the EVSE:

NOTE *This means pay particular attention.* Notes contain helpful suggestions.

NOTE *Cela signifie accorder une attention particulière.* Les remarques contiennent des suggestions utiles.



CAUTION: *This symbol means be careful.* There is potential of doing something that might result in damage to the equipment.



ATTENTION: *Ce symbole signifie être prudent.* Vous êtes capable de faire quelque chose qui pourrait causer des dommages à l'équipement.



WARNING: *This symbol means danger.* This is a situation that could cause bodily injury. Before working on any electrical equipment, be aware of the hazards involved with electrical circuitry and standard practices for preventing accidents.



AVERTISSEMENT: *Ce symbole signifie un danger.* Vous êtes dans une situation qui pourrait causer des blessures corporelles. Avant de travailler sur un équipement électrique, être conscient des dangers présentés par les circuits électriques et les pratiques courantes de prévention des accidents.

Instructions Pertaining to Risk of Fire or Electric Shock

When using the CS, basic electrical safety precautions should be followed:

- Use this EVSE to charge electric vehicles equipped with an *SAE-J1772TM charge port only*. Consult the vehicle owner's manual to determine if the vehicle is equipped with the correct charge port.
- Make certain the EVSE *SAE-J1772TM* cable is positioned so it will not be stepped on, tripped over, or otherwise subjected to damage or stress.
- This product contains no user serviceable parts. Consult the Customer Support section in this manual for service information. Do not attempt to repair or service the EVSE.
- Do not operate the EVSE if it or the *SAE-J1772TM* charge cable is physically open, cracked, frayed, or otherwise visibly damaged. Contact a Service Representative for service immediately. Consult the Customer Support section in this manual for information on the Service Representative in the area.
- Not for use in commercial garages where a **COMMERCIAL GARAGE** is defined as a facility (or portion thereof) used for the repair of internal combustion vehicles in which the area may be classified due to flammable vapors being present (such as from gasoline).
- Do not place fingers inside of the coupler end of the *SAE-J1772TM* charge cable.
- Do not allow children to operate this device. Adult supervision is mandatory when children are in proximity to an EVSE that is in use.

Instructions Relatives au Risque d'Incendie ou de Choc Électrique

Lorsque l'utilisation de la CS, précautions fondamentale de sécurité électrique doivent être suivies:

- Utilisez cette EVSE pour charger les véhicules électriques équipés d'un SAE-J1772™ port de recharge seulement. Consultez le manuel du propriétaire du véhicule afin de déterminer si le véhicule est équipé d'un correcte port de recharge.
- Assurez-vous que le SAE-J1772™ câble de recharge sur la EVSE est positionné de telle sorte qu'il ne sera pas piétiné, accroché plus de, ou autrement endommagé ou de subir le stress.
- Ce produit ne contient aucune pièce réparable par l'utilisateur. Consultez la section Support à la Clientèle dans ce manuel pour obtenir des informations de service. N'essayez pas de réparer ou d'entretenir la EVSE vous-même.
- Ne faites pas fonctionner votre station ou le câble de recharge si elles sont physiquement ouverte, fissuré, effiloché, ou autrement visiblement endommagé. Contactez votre représentant du service pour service immédiatement. Consultez la section Support à la clientèle dans ce manuel pour obtenir des informations sur le représentant du service dans votre région.
- Ne pas utiliser dans les garages commerciaux où un garage commercial est défini comme une installation (ou une partie) utilisé pour la réparation de véhicules à combustion interne dans lequel la zone peut être classée en raison de vapeurs inflammables étant présents (Tels que de l'essence).
- Ne posez pas les doigts à l'intérieur de l'extrémité du SAE-J1772™ coupleur du câble de recharge.
- Ne pas laisser les enfants utiliser cet appareil. Supervision d'un adulte est obligatoire lorsque des enfants sont à proximité d'une EVSE qui est en cours d'utilisation.

ADDITIONAL SAFETY INFORMATION



WARNING: Turn off input power to the EVSE at the circuit breaker panel before servicing or cleaning the unit.



AVERTISSEMENT: Couper l'alimentation d'entrée à votre EVSE sur le panneau de disjoncteur avant de nettoyer ou de réparer l'appareil.

NOTE VENTILATION: Some electric vehicles require an external ventilation system to prevent the accumulation of hazardous or explosive gases when charging indoors. Consult the vehicle owner's manual to determine if the vehicle requires ventilation during indoor charging.

NOTE VENTILATION: Certains véhicules électriques nécessitent un système de ventilation externe pour éviter l'accumulation de gaz explosifs ou dangereux lors de la charge à l'intérieur. Consultez le manuel du propriétaire du véhicule pour déterminer si votre véhicule nécessite une ventilation quand le recharge en salle.

NOTE Vehicles which conform to the *SAE-J1772TM* standard for communication can inform the EVSE that they require an exhaust fan. The EVSE is not equipped to control ventilation fans. Do not charge the EV with the EVSE if ventilation is required.

NOTE Véhicules qui sont conformes à la norme *SAE-J1772TM* de communication peuvent informer la EVSE qu'ils nécessitent un ventilateur d'extraction. Le EVSE n'est pas équipé pour contrôler les ventilateurs. Ne chargez pas le véhicule avec les EVSE si la ventilation est nécessaire.



CAUTION: DO NOT CHARGE an EV indoors if it requires ventilation. Contact a Service Representative.



ATTENTION: NE PAS RECHARGER un véhicule à l'intérieur si il nécessite une ventilation. Contactez votre représentant de service pour plus d'informations.

**Save these instructions for future reference.
Conservez ces instructions pour référence future.**

FCC INFORMATION

This device complies with Part 15 of the FCC rules. Operation is subject to the following two conditions: (1) This device may not cause harmful interference, and (2) This device must accept any interference received, including interference that may cause undesired operation.

This product has been designed to protect against Radio Frequency Interference (RFI). However there are some instances where high powered radio signals or nearby RF-producing equipment (such as digital phones, RF communications equipment, etc.) could affect operation.

If interference to the EVSE is suspected, we suggest the following steps be taken before consulting a ClipperCreek Sales and Service Representative for assistance:

1. Reorient or relocate nearby electrical appliances or equipment during charging.
2. Turn off nearby electrical appliances or equipment during charging.



CAUTION: Changes or modifications to this product by other than an authorized service facility may void FCC compliance.



ATTENTION: Modifications apportées à ce produit par qui conque autre qu'un centre de service autorisé peut annuler la conformité FCC.

OPERATION

The CS-100 is a conductive EVSE that provides the electric vehicle (EV) user with a safe and manageable link between the power grid and the electric vehicle.

Remove the charging connector from its holder, and plug it into the vehicle's charge port. If there is a mechanical latch that holds the connector firmly while charging, be sure the latch has "clicked" into place. Normally, the vehicle will immediately request a charge, the Green CHARGING light will come on, and charging will begin. After an average driving day, it will require a few hours to recharge completely. Charging overnight is the most convenient way to ensure the vehicle's full range will be available for the next day.

If the vehicle has stopped charging, the Green CHARGING light will be off. Remove the cable and the vehicle is ready to use. If the charging is still in progress, first push the START/STOP button on the CS-100 front panel. The charging light will start blinking and the EV charge connector can be removed.

Front Panel

The front panel of the CS-100 has one GREEN and one RED light to indicate the status of the unit. The operational state of the unit can be determined by looking at the panel lights and comparing them with **Table 1** below.

Table 1. Front Panel Indicators

(Green) CHARGING	(Red) PROTECTION	Status of CS EVSE
OFF	OFF	- Vehicle is not connected - or vehicle is not requesting charge
ON	OFF	- Vehicle is charging at 80A
OFF	ON	- The ground fault is tripped - or the ground is missing - or service is required
ON	ON	- There is a problem on the vehicle
blink	OFF	- charging interrupted by the user - or charging disabled by external timer - or unit is in Cold Load Pickup

Figure 1. The CS-100 Front Panel



In Case of Difficulty

ClipperCreek recognizes that this EVSE will be heavily relied upon to charge an electric vehicle for daily transportation needs. Therefore, every effort will be made to restore service should problems arise.

In the event of a problem, charging will stop and the Red PROTECTION light will turn on. If this happens, please try the two simple steps below before calling a Service Representative.

1. Remove the cable connector from the vehicle socket. The Red PROTECTION light may turn off. If it does turn off, plug the connector back into the socket, and see if charging begins normally.
2. If the Red PROTECTION light *does not* go out when the connector is removed, be sure the connector is removed from the vehicle socket and switch off power at the circuit breaker feeding power to the CS-100. Wait a few seconds and switch the circuit breaker back on again. If the Red PROTECTION light does not turn on, re-connect the cable to the vehicle. Charging should begin normally. If charging does not begin, or if the Red PROTECTION light turns back on, call a Service Representative.

The information obtained by following the above steps will help the Service Representative determine what the problem is and how best to get the EVSE operational again as quickly as possible.

FEATURES

The following features are supported by the CS-100:

Personnel Protection System: Ground Fault protection with Self-Testing and Auto-Reclosure (see below), no manual resetting or testing is necessary.

Ground Monitoring Circuit: Constantly checking for the presence of a Safety Ground connection.

Auto-Reclosure: If a problem occurs that interrupts charging, the unit will automatically clear all error indications after 5 minutes, and attempt to begin charging again. If the problem is immediately sensed a second time, it will wait another 5 minutes and try again. This process will repeat several times, at which point power will be removed and no further attempt will be made. The Red PROTECTION light on the front panel will be on.

This feature helps ensure that the vehicle will be charged and ready for use when needed. Temporary problem indications such as ground-faults or utility power surges can be overcome automatically without the need for the user to manually re-initiate charging.

Off-Peak Charging: For this feature, an external timer must be installed (purchased separately). A utility may also install a special Time-of-Use meter to provide special rates for Off-Peak Charging. If a timer is installed, it is not necessary to wait until late evening to plug the CS-100 charge connector into the vehicle. The CS-100 may be connected to the vehicle at any time. Even though the vehicle may immediately request a charge, the timer will cause the CS-100 to delay energizing the cable until the specified time period. With this feature, the Green CHARGING light will blink while the vehicle waits for the timer to allow charging.

Making the best use of the Off-Peak Charging feature will require the following:

1. Installation of a Time-Of-Use meter by the electric utility.
2. Installation of a clock/timer to allow the CS-100 to charge only during Off-Peak hours.
3. Connecting the timer's control wire to the High/Off pin on the 4-position terminal block. Refer to **Figure 9**, CS Service Wiring to identify the correct pin.

If this feature is desired, please call the local utility to be sure the Time-of-Use meter is available in the area before having the timer installed. Technical information to help connect the timer to the CS can be found in the Load Management Inputs section of this manual.

NOTE: Many vehicles are equipped with programmable timers for the purpose of setting the charge time independent of the EVSE.

Cold Load Pickup: This feature is built-in to the CS-100, but will only be apparent when the utility power fails during charging. If the charging connector is still plugged into the vehicle when utility power is restored, the Green CHARGING light will blink and the unit will not energize the cable for a random time between 2 and 12 minutes. This is to prevent the utility's grid from experiencing a large surge at turn-on, allowing electric vehicles in the area to begin drawing current at random times rather than all at once.

NOTE: The vehicle does not need the owner's attention after a power outage. The CS-100 will automatically resume charging when power is restored.

External Error Indication: Whenever the Red PROTECTION light is on, a relay on the board will provide a contact closure that can be used to remotely indicate that a problem exists. A fleet vehicle yard, for example, could use this feature to light a lamp or ring a bell in the main office, indicating that a vehicle has a charging problem. This early warning helps assure that each vehicle will be properly charged and ready for use when needed. The two rightmost pins on the 4-position terminal block are the relay contacts for the External Error Indication. More information on the Relay Output feature can be found in the Load Management Inputs section of this manual.

Maintenance Current: If the unit is set up for Off-Peak Charging as described above, normal charging current cannot be drawn by the vehicle until the Off-Peak hours. However, the CS-100 can be set up to allow a minimum amount of current while waiting for the timer to allow full-rate charging. This is known as Maintenance Current, used for all power needs on the vehicle except charging the main battery pack. An example would be preheating the cab, or keeping the auxiliary battery topped off. As in the Off-Peak mode above, the Green CHARGING light will flash if the vehicle is connected and waiting for the timer to allow charging. The contactor will close immediately to supply this small amount of power, but the main battery pack will not be allowed to charge.

The Maintenance Current feature can be selected by connecting the Timer's control wire to the High/Low pin on the 4-terminal Terminal Block. Connecting to the High/Off pin will remove all power from the vehicle until the Off-Peak Charging time arrives. Refer to **Figure 9**, CS Service Wiring to identify the correct pin. The other two pins on the terminal block are the relay contacts for the External Indicator.

INSTALLATION - SERVICE CONNECTIONS



CAUTION: This is a single-phase device. DO NOT connect all 3 phases of a 3-phase feed! Any two phases of a 3-phase wye-connected feed can be used. The center-point of the 3 phases (usually used as Neutral) must be grounded somewhere in the system. A current-carrying Neutral is not needed by the CS-100. Only **LINE 1**, **LINE 2**, and **GROUND** are required, as shown in **Figure 3**.



CAUTION: The two phases used must each measure 120V to Neutral. Earth Ground must be connected to Neutral at only one point, usually at the Service Entry Breaker Panel.



CAUTION: If a 240V 3-phase feed is from a Delta-connected secondary, the leg used must have a center-tap. That tap must be Grounded. Only the two phases either side of the center-tapped leg can be used. See **Figure 4**.



Caution: Warranty is void if this unit is wired improperly.



WARNING: Only a qualified electrician should perform the installation. The installation must be performed in accordance with all local electrical codes and ordinances.

Only 3 wires are connected, but care must be taken that the service transformer secondary connection is definitely known, and the 3 wires from the main circuit breaker panel are connected and labeled correctly. **Figures 2, 3, and 4** show the most common service transformer secondary wiring formats.

Notice that **L1, L2 & Ground** are labeled on each diagram. These transformer outputs correspond to the same inputs on the CS-100. Each of the two 3-phase diagrams shows an L3 output, which is not used. **Do not connect all three phases of a 3-phase secondary to the CS. This is a single-phase device.**

The Neutral at the service panel **must** be connected to earth ground **somewhere** in the system on **any** of the three connection arrangements. Ground-fault protection is not possible unless the Neutral (center-tap on the service transformer) is connected to an earth ground. If no ground is provided by the electrical service, a grounding stake must be driven into the ground nearby, following local electrical codes. The grounding stake must be connected to the ground bar in the main breaker panel, and Neutral connected to ground at that point.



WARNING: Local electrical codes must always be followed when installing the grounding stake.

The following diagrams illustrate the 3 service transformer secondary connections most common in the United States.

Figure 2. 220/240V Single Phase

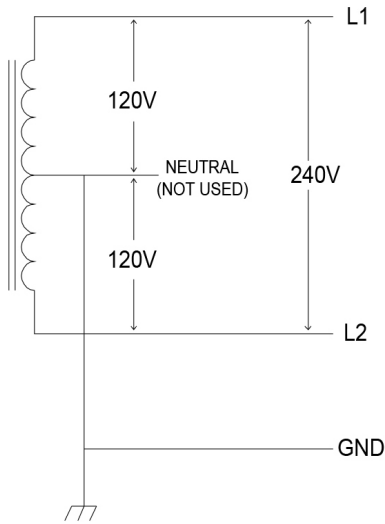
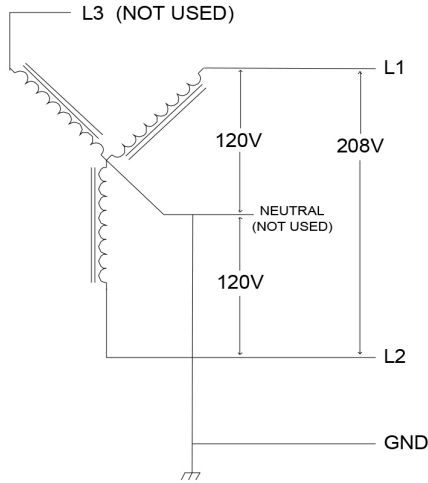
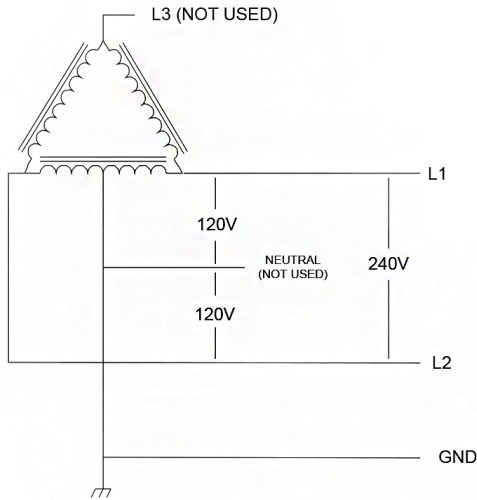

Figure 3. 208V 3-Phase, Wye-Connected

NOTE: With a wye-connected secondary, any two of the legs can be used to provide 208V to the CS-100. For example, **L1 & L2**, or **L1 & L3**, or **L2 & L3**. Leave the unused leg open. **DO NOT** connect it to a Neutral bar or to **Ground**. Be sure the center point is grounded to earth somewhere in the system.

Figure 4. 240V 3-Phase, Delta-Connected, w/Center-Tap on One Leg

CAUTION: With the delta connection, one leg must be center-tapped, and only the two phases on either side of the center tap can be used. The two phases must ***both*** measure 120V to neutral. The third line (L3) of the delta is 208V, with respect to neutral, and is sometimes referred to as a “stinger”. ***Do not use this third line!*** Consult the transformer manufacturer’s literature to be sure the single leg can supply the required power.



CAUTION: A 3-phase delta-connected transformer secondary without a center-tap on one leg is ***not usable with the CS-100***. No “neutral” point is available to be connected to ground for ground-fault protection, and the CS-100 will not allow the contactor to close if it does not sense the presence of a ground wire connected to a “neutral” point on the transformer secondary.

MOUNTING PROCEDURES

1. Locate the wall mounting position of the EVSE:
 - Position the bottom of the EVSE 38 inches above the ground.
 - The mounting holes are spaced 16" apart to accommodate wall studs.
 - If there is no solid structural framing on those centers, an adequate alternative mounting surface for the EVSE must be provided.
2. Attach the EVSE to the wall studs using (4) ¼" x 2 ½" lag screws.
3. Use a multi-set or equivalent if mounting on a concrete wall.
4. Remove the applicable knock-out in the EVSE, push the power leads through the hole, then connect the power conduit to the hole.
5. After mounting, continue the installation by referring to the Wiring Instructions section of this manual.

Figure 5. Wall Mounting of CS

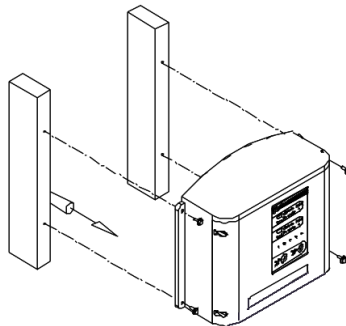
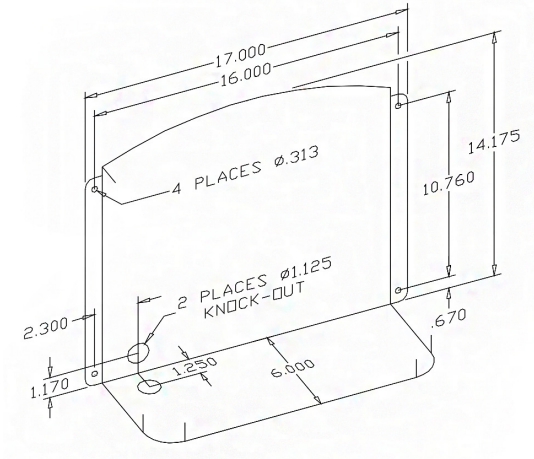

Figure 6. CS-100 Installation Template



Front Door Hidden Latch:

To open the enclosure, perform the following:

1. Unfasten the two (2) machine screws on the left edge of the enclosure lid.
2. Unlatch the hidden latch located underneath the enclosure inside of the connector compartment.

Figure 7. Front Door Hidden Latch

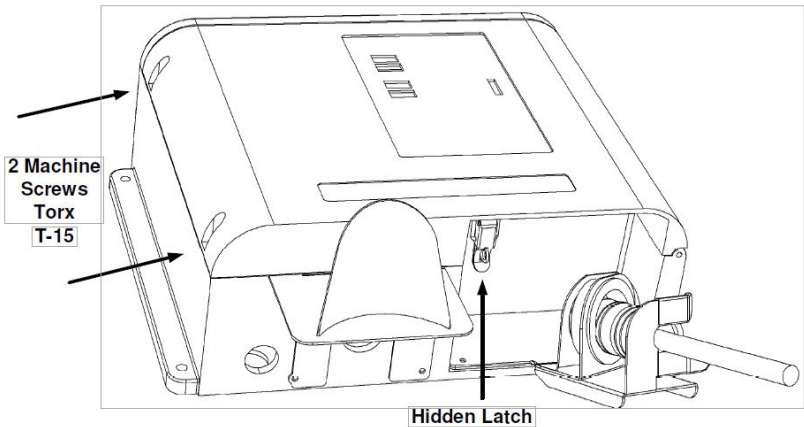

NOTE: A T15 or T20 Torx driver is needed to open the door.

WIRING INSTRUCTIONS

Before connecting wires to the CS-100, carefully review the Installation - Service Connections section of this manual. If unsure of the type of power provided at the service panel, please consult with the local utility or call a Customer Service Representative for assistance.

Figure 8. CS-100 Service Wiring

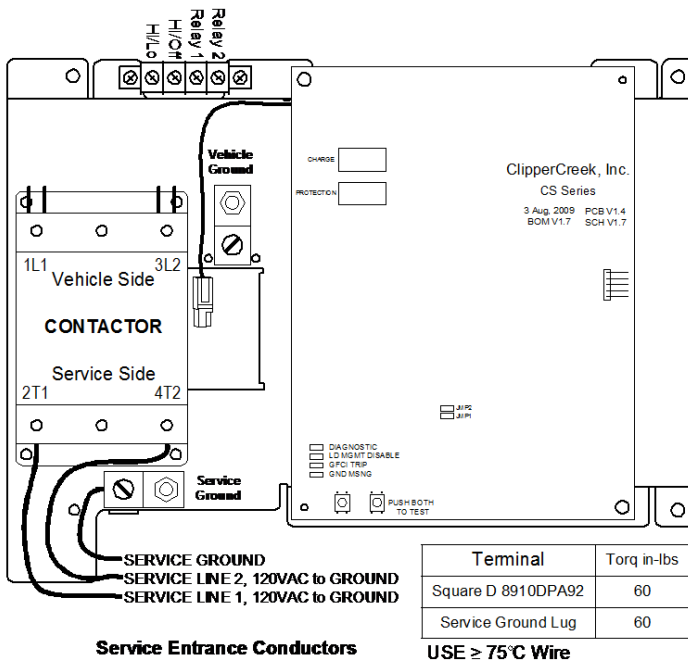

- The CS-100 requires a dedicated 208/240V AC 50/60 Hz, single-phase circuit.
- Do not use a GFCI breaker with the CS-100. The CS-100 contains a Personnel Protection circuit that is the equivalent and specifically designed for use with electric vehicles.
- Only 3 wires are needed to wire the CS: **LINE 1**, **LINE 2**, and **SERVICE GROUND**, as shown in **Figure 8**. Wire the unit from the breaker panel using wire sized in accordance with local electrical codes. The circuit breaker should be rated at 25% over the EVSE's max continuous output.
- The **LINE 1** and **LINE 2** phases are terminated on the input side of the contactor itself, as shown in **Figure 8**. The **SERVICE GROUND** is terminated on the Ground Terminal at the bottom of the enclosure.
- Be careful not to damage the PC Board when removing the power-entry knock-out, attaching the conduit, or when wiring the service conductors to the contactor.

Testing After Installation

- Apply utility power, and observe that only the Diagnostic LED is flashing on the circuit board. If it is not flashing, the board may be defective.
- The two Charge Test buttons on the PC board simulate a connection to the vehicle. Simultaneously press and hold on the two Charge Test buttons. The contactor should close and the large Green CHARGING light should turn on.
- If a vehicle is available, connect the CS-100 to the vehicle and verify that the contactor closes and the Green CHARGING light turns on.
- Once the installation has been tested, close the enclosure door and re-secure the latch. Reinsert the two Torx screws on the left-hand side and hand-tighten them with a T15 Torx L driver until snug.

Installation is complete.

FOR THE SERVICE TECHNICIAN

There are four small LEDs on the PC board to help diagnose problems:

Diagnostic: This is the “heartbeat” of the system. When only this LED is slowly flashing, the system has not detected any failures. If it is on but not flashing, the board is defective. If it is not on, either no power is applied or the board is defective.

To test the system, press and hold the two Charge Test buttons simultaneously. If the contactor closes, the CS-100 is operating normally. Connect the charging cable if a vehicle is available. The contactor should close. If not, the charging cable or vehicle socket may be defective or the vehicle is not requesting a charge.

If the CS-100 detects an internal failure, the Diagnostic LED will blink at a faster rate. One of the other LEDs may also be on and indicate the nature of the problem, such as an inoperative Ground Fault circuitry or a missing Service Ground.

Load Management Disable: This status indicator LED will turn on in conjunction with a slow-blinking Diagnostic LED when either the Cold Load Pickup or External Timer mode is active. This is not a failure mode, merely a status indicator. If a vehicle is connected, the front panel Green CHARGING light will blink when the Load Management Disable LED is on. If a vehicle is not connected, the Green CHARGING light will not activate.

GFCI Trip: This Diagnostic LED is on when the unit has detected a ground fault. When a fault has occurred the contactor will open, the front panel Red PROTECTION light will turn on and the Diagnostic LED will blink at a faster rate. The system waits 5 minutes after sensing a fault, then automatically attempts recovery. After several such attempts, the unit will remain in Protection mode.

If a ground fault error or an EV connection error has been detected:

1. Disconnect the EV charge cable from the vehicle's inlet charge port.
2. Inspect the EV charge cable connector and the vehicle's inlet charge port. Be sure both are clean and undamaged.
3. Reconnect the EV charge cable connector to the vehicle's inlet charge port.
4. If the fault condition persists, a problem may exist on the vehicle. Refer to the vehicle owner's manual for instructions on inspecting and cleaning the inlet charge port.
5. If the charge cable connector and vehicle charge port appear to be in good condition and the error condition does not clear, contact a Customer Service Representative.

Ground Missing: On when the unit has detected a missing Service Ground. The CS-100 will not close the contactor until a proper Service Ground has been connected. The front panel Red PROTECTION light will be on, and the Diagnostic LED will be flashing at a faster rate.

NOTE: If a missing Service Ground is discovered, power should be turned off before re-connecting the Service Ground. If Service Ground is reconnected without turning off the power, it will be necessary to wait 5 minutes for the CS-100 to clear the Ground Missing error.

Table 2 below illustrates the information that can be obtained from the 4 LEDs on the PC board.

Table 2. PC Board Diagnostic LEDs

Status	LED 1	LED 2	LED 3	LED 4
	Diagnostic Blink Rate	Load Mgmt Disable	GFCI Trip	Ground Missing
Normal Operation	slow	--	--	--
Charging	slow	--	--	--
Charge Disabled	slow	ON	--	--
CCID Trip	fast	--	ON	--
Ground Missing	fast	--	--	ON
Service Required	fast	--	--	--

NOTE: A (--) symbol indicates the LED is off.

MAINTENANCE

The CS-100 requires no periodic maintenance other than occasional cleaning.



WARNING: To reduce the risk of electrical shock or equipment damage, exercise caution while cleaning the unit and the EV charge connector cable.

1. Turn off the EVSE at the circuit breaker before cleaning.
2. Clean the EVSE using a soft cloth lightly moistened with mild detergent solution. Never use any type of abrasive pad, scouring powder, or flammable solvents such as alcohol or benzene.



AVERTISSEMENT: Pour réduire le risque de choc électrique ou des dommages équipement, user de prudence lors du nettoyage de l'appareil et le câble du connecteur de charge EV.

1. Eteignez la équipement au disjoncteur avant de le nettoyer.
2. Nettoyez l'équipement à l'aide d'un chiffon doux légèrement humidifié avec une solution de détergent doux. Ne jamais utiliser de tampons abrasifs, de poudre à récurer ou de solvants inflammables tels que l'alcool ou le benzène.

SPECIFICATIONS

Line Input Power - Service Entrance

Voltage & Wiring: 240V AC Single-phase - L1, L2, and Safety Ground.
208V AC 3-phase, Wye-Connected - Any 2 phases, and Safety Ground.
240V AC 3-phase, Delta-Connected. With center-tap on one leg, must use only the two phases on both measure 120V AC to ground.
Do not use the third leg (208V “Stinger”).

Frequency: 50/60 Hz

CCID: 20mA

Current & Output 100A Circuit Breaker., The maximum current for the vehicle is 80A, set by the duty cycle of the Pilot waveform.

Dimensions:

Height 304 mm (12 in)
Width 457 mm (18 in)
Depth 203 mm (8 in)

Color: Gray

Cable Length: Approximately 7.6 m (25 ft)

Weight (with cable): 16.5 kg (36 lbs)

Environment:

Operating Temperature -40°C (-40°F) to +50°C (+122°F)
NEMA Rating NEMA 4 - outdoor use, watertight

Timer Connection: Ground to disable charging, leave open to charge. 12 volts with 1K source resistance when open circuit, 12mA sink current when grounded.

Error Relay Contacts: Dry contact, 24V AC/DC max, 5A current max, closed if error present.

Agency Approvals: cULus, cETLus, FCC Part 15 Class B

LOAD MANAGEMENT INPUTS

If the CS-100 has been configured for Off-Peak Charging, the Green CHARGING light may blink after the EV charge cable is plugged into the vehicle. If the vehicle does not charge in this mode it may indicate that a timer or other device has been connected to the Hi/Off input on the 4-position terminal block. In this case, charging will not occur until a specified time such as later in the evening when electrical rates are lower. To override this feature and begin charging immediately, push the Start/Stop button.

Pressing the button will alternately Stop and Re-Start charging. The button will not initiate charging unless the cable is connected, and the vehicle is requesting a charge.

There are two Load Management inputs, labeled Hi/Low and Hi/Off, on a terminal block as shown in **Figure 9** below. Grounding Hi/Off will completely inhibit charging until it is released from ground. Grounding Hi/Low will tell the EVSE to send a signal to the vehicle instructing the vehicle that that a reduced power level is available for auxiliary uses such as cooling the battery pack, or pre-heating the vehicle cab.

Figure 9. 4-Position Terminal Block

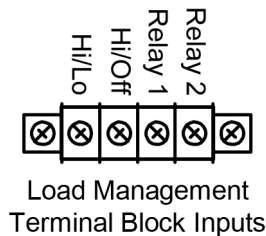

RELAY OUTPUT

The two rightmost terminals labeled Relay 1 & Relay 2 are dry contacts that are normally open. If the Protection light turns on, or other internal problems are sensed by the CS-100's computer, these contacts will close. This can be used to power a remote indicator to warn the user that a problem exists, giving them the opportunity to correct the problem and help ensure the vehicle will be charged when needed.

CS CABLE WRAP GUIDELINES

The EVSE has a cable storage saddle located on the lower left-hand side of the EVSE to allow the charge cable to be wrapped around it for convenient storage as well as to keep the bulk of the cable off of the ground and out of the way. As the charge cable is comprised of a number of wires, coiling the charge cable too tightly around the CS-100 saddle will result in the charge cable feeling warmer to the touch than would ordinarily be the case.

To minimize this effect, it is recommended that the charge cable be loosely coiled on the saddle with larger loops. This will also permit greater convenience in “pulling off” additional loops if a longer charge cable reach is desired. See **Figure 10**.

Figure 10. Wrap the Charge Cable Loosely

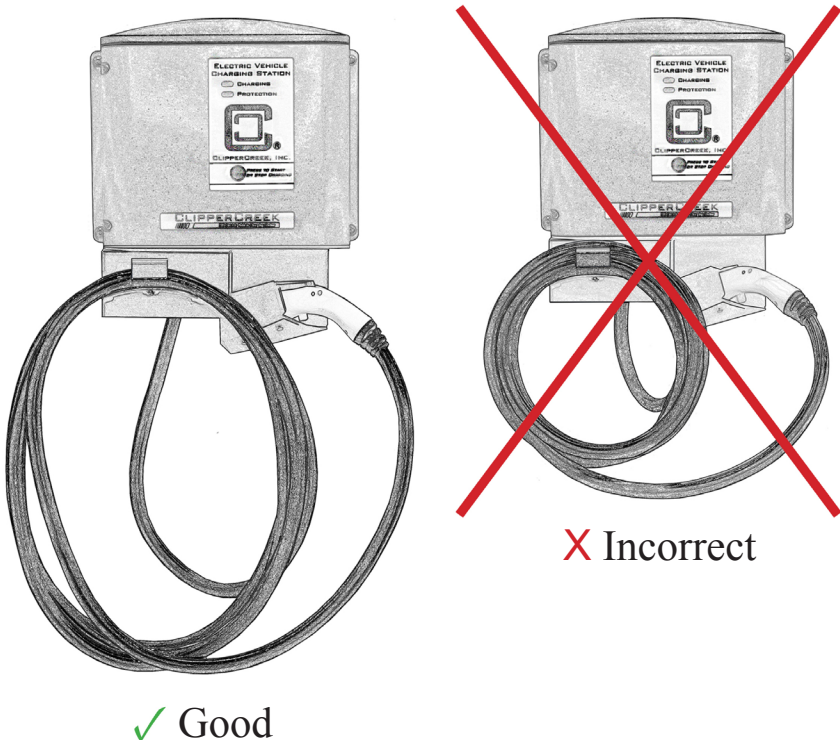

CUSTOMER SUPPORT

Call a Customer Service Representative at any time, 24 hours a day, at the number below. **PLEASE HAVE THE MODEL NUMBER AND SERIAL NUMBER AVAILABLE WHEN YOU CALL.** These can be found on the side of the enclosure. If a call is made after business hours or on weekends, please leave name, telephone number, the unit's serial number, and a brief description of the problem. A Customer Service Representative will call back at the earliest opportunity.

**Distributor
Place Contact Information
Sticker Here.**

TO CONTACT CLIPPERCREEK, INC. DIRECTLY FOR SERVICE, CALL (877) 694-4194 MONDAY THROUGH FRIDAY BETWEEN 8:00AM AND 5:00PM STANDARD TIME.

WARRANTY INFORMATION

LIMITED WARRANTY ELECTRIC VEHICLE SUPPLY EQUIPMENT and ACCESSORIES

ClipperCreek, Inc.
11850 Kemper Road
Auburn, California 95603
Phone: (877) 694-4194
Email: information@clippercreek.net

ClipperCreek shall provide the following warranty with respect to the Products to Representative, its Sub-Representatives and their customers:

Product 1-year parts, 1-year factory labor:

ClipperCreek, Inc. warrants this product to be free from defects in material and workmanship. The warranty period shall commence on the date of installation date (first use). The product installation date must be evidenced and communicated to ClipperCreek by way of the warranty registration card (or its equivalent). The warranty registration card must be filled out completely and accurately, and returned to ClipperCreek within 30 days after installation, and the product installation date shall be within 6 months after the purchase date. If a Product installation date is not communicated to ClipperCreek as described above, the product purchase date shall serve as the warranty commencement date.

If this product is defective in materials or workmanship during the warranty period, ClipperCreek will, at its option, repair or replace the product. Repair parts and/or replacement products may be either new or reconditioned at ClipperCreek's discretion. This limited warranty does not cover service or parts to repair damage due to improper installation or use, including but not limited to improper connections with peripherals, external electrical faults, accident, disaster, misuse, abuse or modifications to the product not approved in writing by ClipperCreek. Any service repair outside the scope of this limited warranty shall be at applicable rates and terms then in effect. This warranty covers factory parts and factory labor only; it does not cover field service or removal and replacement of the product or any other costs.

All other express and implied warranties for this product including the warranties of merchantability and fitness for a particular purpose are hereby disclaimed. Some states do not allow the exclusion of implied warranties or limitations on how long an implied warranty lasts, so the above limitation may not apply. If this product is not as warranted above, your sole and exclusive remedy shall be repair or replacement as provided above. In no event will ClipperCreek, any of its authorized sales and service representatives, or its parent company be liable to customer or any third party for any damages in excess of the purchase price of the product. This limitation applies to damages of any kind including any direct or indirect damages, lost profits, lost saving or other special, incidental, exemplary or consequential damages whether for breach of contract, tort or otherwise or whether arising out of the use of or inability to use the product, even if ClipperCreek or an authorized ClipperCreek representative or dealer has been advised of the possibility of such damages or of any claim by any other party. Some states do not allow the exclusion or limitation of incidental damages for some products, so the above limitation or exclusion may not apply. This warranty gives you specific legal rights, and you may also have other rights which may vary from state to state.

To obtain warranty service:

Call the nearest authorized Service Representative or ClipperCreek at the above number. You will receive information as to how service for the product will be provided. If you mail or ship the product in for service, you must insure the product, prepay all shipping charges, and properly pack it for shipment in its original shipping container or its equivalent. You are responsible for all loss or damage that may occur in transit. You must provide proof of purchase of the product and the purchase date before any warranty service can be performed.

This page was left intentionally blank.

This page was left intentionally blank.

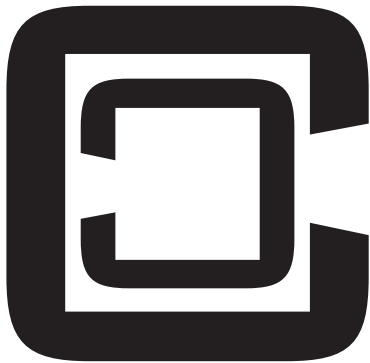

CLIPPERCREEK, INC.
11850 KEMPER RD., SUITE E
AUBURN, CA 95603
WWW.CLIPPERCREEK.COM
(877) 694-4194



WALL MOUNTED CABLE MANAGEMENT INSTALLATION GUIDE

PLEASE NOTE:

This installation guide includes the latest information at the time of printing. ClipperCreek, Inc. reserves the right to make changes to this product without further notice. Changes or modifications to this product by other than an authorized service facility may void the product warranty.

Before Beginning:

Read these instructions completely, including the Safety Instructions. If there are questions about the use of this product, please contact a Service Representative.

Note to the Installer:

Be sure to leave these instructions with the user.

Note to the User:

Keep these instructions for further reference.

Tools Required for Assembling the Wall Mounted Cable Management System

The following tools are required for the installation and assembly of the Wall Mounted Cable Management Kit components.

- #2 Phillips Head Screwdriver
- 1/4" Slotted Screwdriver
- 5/16" Allen Wrench
- Those tool(s) most appropriate for the supporting structure and hardware chosen.

Wall Requirements

The location, dimensions and composition of the mounting surface must comply with building codes. **Use the type of mounting hardware most appropriate for the supporting structure.**

- 2 1/2" lag bolts or longer with washers are recommended for use with strong wooden frames
- Solid surfaces such as concrete, brick, or stone will require solid-wall mounting hardware such as multi-sets, wedge anchors or sleeve anchors.

Packing List

The following items are included in the Wall Mount Kit

- (1) Wall Mount Bracket
- (1) Cable Retractor Box
- (2) Hex Head Cap Screws 3/8"-16 Thread, 3/4" Long
- (2) 3/8" Split Lock Washers
- (1) Hose Clamp Package A (includes one (1) Hose Clamp A, four (4) #5 Phillips screws 5/8" long, one (1) 10-32 x 1 1/4" long scrow, and one (1) 10-32 nut)
- (1) Alternate Hose Clamp B (includes one (1) Hose Clamp B, four (4) #5 Phillips screws 5/8" long, one (1) 10-32 x 1 1/4" long scrow, and one (1) 10-32 nut)

1. Assemble the Retractor Mount

- Place a 3/8" Split Lock Washer around the shaft of each of the two (2) 3/8"-16 Thread, 3/4" Length Hex Head Cap Screws.
- Align the two holes in the Wall Mount Bracket with the threaded inserts of the Cable Retractor Box.
- Secure the Cable Retractor Box to the Wall Mount Bracket with the two (2) Hex Head Cap Screws and lock washers using a 5/16" Allen wrench.

Figure 1: Retractor and Wall Mount Bracket Assembly

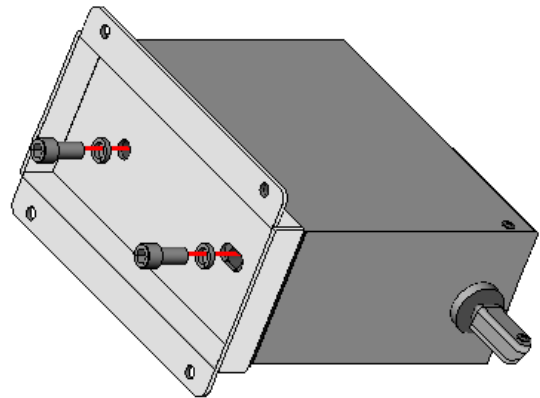

2. Secure the Retractor Assembly to the Wall

The Wall Mount Bracket should be mounted as close to the charging station as possible without interfering with vehicle or pedestrian traffic. This will ensure vehicle and pedestrian safety as well as provide the maximum reach of the EVSE (Electric Vehicle Supply Equipment) charge cable. Use the type of mounting hardware most appropriate for the supporting structure and always adhere to local codes. Refer to Figure 2.

Figure 2: Secure Bracket Assembly to Wall
(Repeat for other side: four bolts total)

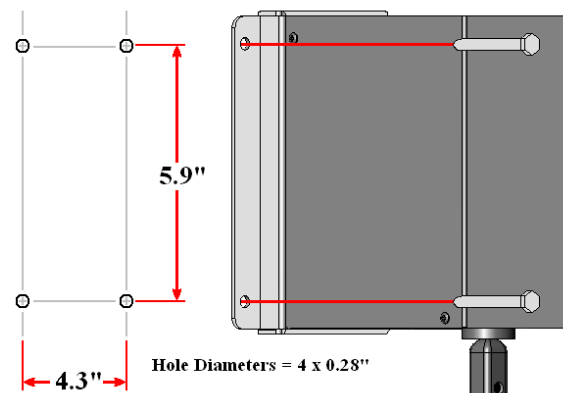

3. Attach the Hose Clamp

The cable management system requires that a hose clamp be attached to the EVSE charge cable and then to the Cable Retractor Box.

- The position on the EVSE charge cable where the hose clamp should be attached will depend upon the location of the Wall Mount Bracket in relation to the charging station. The purpose is to keep the EVSE charge cable off the ground where it exits the charging station. There should be no loops and very little sag in the EVSE charge cable between the charging station and the hose clamp. See Figure 3.

Figure 3: Positioning of the Hose Clamp

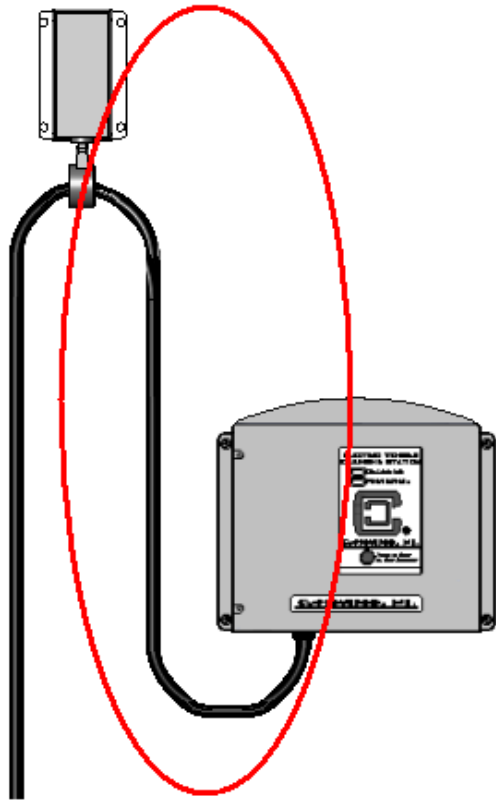

For correct cable management, there should be no loops and very little sag between the Charging Station and the Retractor Hose Clamp as shown.

- Two hose clamp sizes are provided. The CS-40 and lower amperage models use the hose clamp with two holes (Hose Clamp A). The CS-50 and higher amperage models use the hose clamp that has one hole (Hose Clamp B). See Figure 4 for Hose Clamp selection.
- Secure the hose clamp to the EVSE charge cable by tightening the four (4) #5 Phillips screws 5/8" long with a #2 Phillips screwdriver. Refer to Figure 4.

Figure 4: Hose Clamps

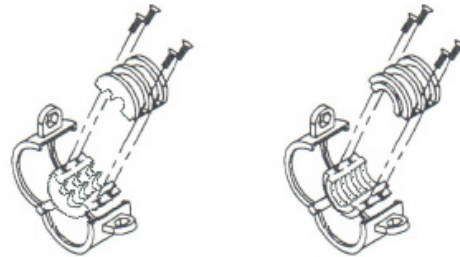
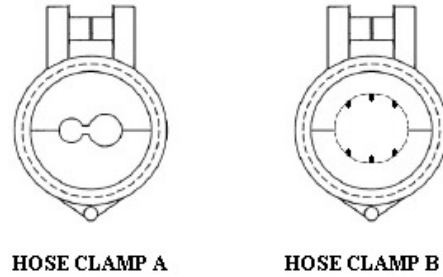

CS-40 and lower amperage charging stations require Hose Clamp A.
CS-50 and higher amperage charging stations require Hose Clamp B.

- The hose clamp should not be moved once it is clamped onto to the EVSE charge cable. Do not try to pull or force the hose clamps into another position. If repositioning is required, remove the hose clamp completely and repeat the steps above.
- To connect the hose clamp to the Retractor Assembly, use the plastic coupler which is secured at the end of the Retractor cord.
- Fasten the hose clamp tightly to the plastic coupler using the 10-32 x 1 1/4" long screw and 10-32 nut provided in the hose clamp kit as shown in Figure 5.

Figure 5: Plastic Coupler

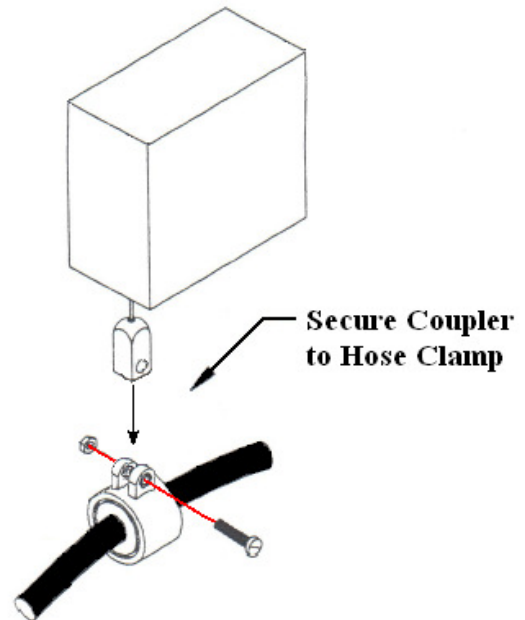

4. Wrap Remaining EVSE Charge Cable

There is usually excess EVSE charge cable remaining.

- The EVSE charge cable hanger is provided to wrap this excess around as needed.
- Insert the vehicle connector into the holster.
- Fig 6 shows an example of a completed installation.

5. Adjust Retractor Box Cord Tension

To obtain proper tension for your specific installation, the Retractor Box cord tension should be adjusted with the EVSE charge cable already attached. The recommended procedure for adjusting tension of the Retractor Box cord is as follows:

- The protective cover must be removed from the Retractor Box. Remove the four Phillips screws using a #2 Phillips screwdriver and pull the cover off.
- **WARNING: Use caution when adjusting tension! The stored energy from the winding must be safely restricted while performing this adjustment.**
- Remove one loop at a time from the retractor reel until there is a slight droop in the retractor cord and it does not fully retract when unsupported.
- **IMPORTANT: Add one loop back in** to achieve full retraction while providing the lowest tension possible for end users.



Figure 6: Wrap Excess EVSE Charge Cable over Hanger

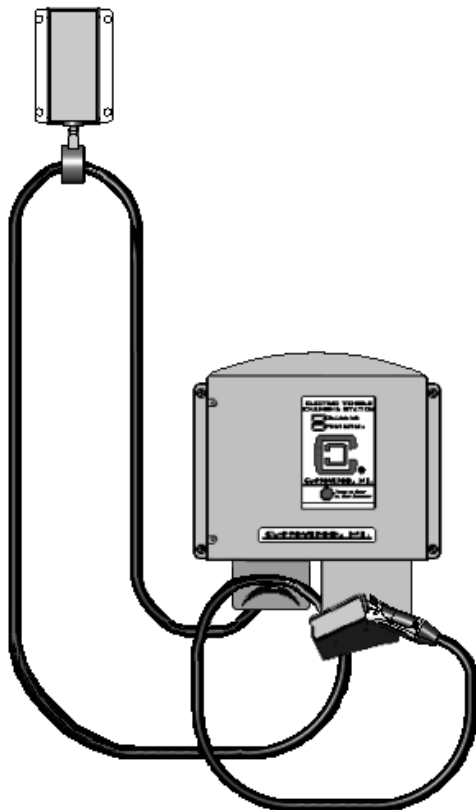

Visit us at www.clippercreek.net

Wall Mount Cable Management
Installation Guide Version 1.5
December, 2013